



// ONE BRAND // ONE SOURCE // ONE SYSTEM



REMACLEAN
Belt Cleaning Systems

Copyright © 2023 REMA TIP TOP AG

All information is prepared to the best of our knowledge and belief. Nevertheless all data are to be regarded as non-binding information. There is no right to damages. We reserve the right to change technical specifications without prior notice for improving the products.

The information presented here is based on technical empirical values, but cannot guarantee product sustainability in specific applications and does not release the user from the responsibility to carry on own examinations, also as far as trade mark rights of third parties are concerned.

In case of use in special applications and under operating conditions characterized by temperature effects, UV radiation, exposure to ozone, acids and alkaline solutions, effects of dynamic and static forces, tensile stresses, expansions and other influences, we recommend to obtain technical application-related advice.

1.	U-Series – for belt return side applications	4
1.1	HM-U1	4
1.2	HM-U2	5
1.3	HM-U3	6
1.4	HM-U7	7
1.5	HM-U8	8
1.6	HM-U9	9
1.7	HM-U10	10
1.8	HM-U10 S	11
1.9	HM-U11 R	12
1.10	HM-U500	13
2.	F-Series – for use on the pulley	14
2.1	HM-F2	14
2.2	HM-F2 PUR	15
2.3	PUR-F3	16
2.4	PUR-F4	17
2.5	PUR-F4 HD	18
2.6	PUR-F5	19
2.7	PUR-F6	20
2.8	PUR-F8	21
2.9	PUR-F300	22
2.10	PUR-F400	23
2.11	PUR-F500	24
3.	I-Series – for use on the inner belt	25
3.1	IGD HD	25
3.2	RB-IGD	26
3.3	RB-IGP-S	27
3.4	RB-IGP-S HD	28
4.	Belt cleaning brushes	29
4.1	SGB	29
4.2	SGB-PUR	30
4.3	SGF	31
4.4	TMB	32
4.5	GRB	33
4.6	GBM	34
5.	Cleaning bars	35
5.1	KWA	36
5.2	PUR	37
5.3	PUR-LIGHT	38
5.4	M	39
5.5	C	40
5.6	HML	40
6.	Overview	42
6.1	U-Series	42
6.2	F-Series	44
6.3	I-Series	46
6.4	Belt cleaning brushes	47
6.5	Cleaning bars	48
7.	Questionnaire	50
	REMACLEAN belt cleaning systems	50

REMA TIP TOP – Your partner for conveyor belt cleaning systems



Increase your productivity – with REMACLEAN conveyor belt cleaning systems made by REMA TIP TOP!

The cleaning of conveyor belts is a matter that is often neglected by many plant operators. Optimum cleaning, however, considerably contributes to economic efficiency because: interruptions of the production process caused by soiling/contamination can lead to inefficiency and even to a standstill of the entire belt conveyor system. In addition, inadequate cleaning of the belt causes additional costs, for example through increased wear on pulleys or belt, loss of bulk material and expenses for manual cleaning work.

Reductions in plant availability and maintenance costs that can be avoided are no longer acceptable to operators.

Therefore, the demands made on the manufacturers of conveyor belt cleaning systems are clearly formulated:

- Optimum cleaning results, simultaneously protecting the belt
- Efficient installation and maintenance
- Long service life of the belt cleaning systems

Conveyor belt cleaning is a complex matter. Several factors must be simultaneously met in order to achieve good and economically efficient cleaning results:

- Selection of a suitable belt cleaning system for the specific application
- Combination of the right systems (pre- and fine cleaning)
- Optimum positioning of the system in the belt conveyor system
- Installation by trained technicians
- Definition and execution of regular maintenance work by trained technicians

If any one of these items is not fulfilled, even the best system will fail after a short time and therefore will not contribute to economic operation.

REMA TIP TOP is your competent partner for the selection, installation and maintenance of belt cleaning systems – and much more. REMA TIP TOP has suitable products and services for all areas of belt conveyors. Our experienced specialists advise on, develop and optimize your conveying systems. Our comprehensive service network guarantees the availability of trained technicians – at any time.

Our modern training center for conveyor belt cleaning in Nauen, near Berlin, provides both, seminar rooms for the teaching of theoretical knowledge and original scraper systems for practical installation and maintenance training on a conveyor belt system.

REMACLEAN HM-U1

U-Series – for belt return side applications

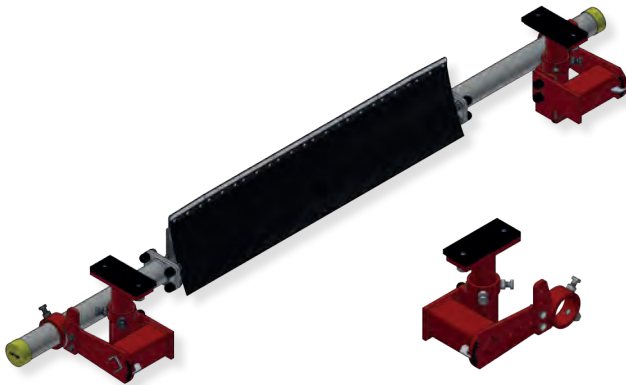

This system is suitable for cleaning the conveyor belt in the return side of the belt for speeds up to 6.5 m/s. The design of the **REMACLEAN HM-U1** carbide blade perfectly adjusts to the belt, thus providing an effective and belt-friendly cleaning. The design of the carbide blade, as well as its anti-caking coating made of polyethylene, guarantee extended service life and high reliability. Precise pre-tensioning and subsequent control is ensured thanks to the spindle-type tension unit and an integrated scale.

Benefits

- High cleaning efficiency due to optimal contact of the tungsten carbide blade
- Long service life due to the use of highly wear-resistant carbide
- Protection of the carrier body due to run-off aprons at the segments
- Easy to fit and adjust
- Low maintenance

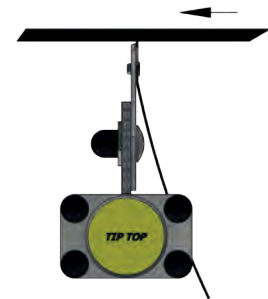

Technical Data

Conveyor Belt Width [mm]	Weight [kg]	A [mm]	B [mm]	C [mm]
400	31.6	360	600 – 1,215	1,400
500	33.3	480	720 – 1,315	1,500
650	34.9	600	840 – 1,465	1,650
800	47.0	720	960 – 1,500	1,700
1,000	50.6	960	1,200 – 1,750	2,000
1,200	85.2	1,080	1,330 – 2,370	2,700
1,400	89.4	1,200	1,450 – 2,570	2,900
1,600	150.6	1,440	1,700 – 2,696	3,100
1,800	160.1	1,680	1,900 – 2,896	3,300
2,000	182.7	1,800	2,100 – 2,896	3,500
2,200	191.1	2,040	2,300 – 3,146	3,750
2,400	199.4	2,280	2,500 – 3,396	4,000
2,600	210.0	2,520	2,700 – 3,596	4,200

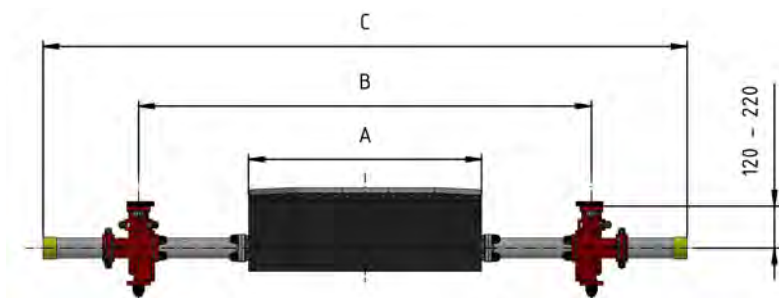

REMACLEAN HM-U2

U-Series – for belt return side applications

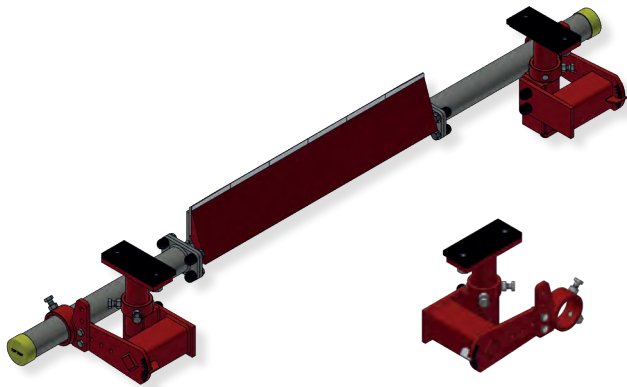

This system is suitable for cleaning the conveyor belt in the return side of the belt for speeds up to 6.5 m/s. The carbide blade of the **REMACLEAN HM-U2** allows an effective cleaning. The design of the carbide blade with its anti-caking coating guarantees extended service life and high reliability. Precise pre-tensioning and subsequent control is ensured thanks to the spindle-type tension unit and an integrated scale.

Benefits

- High cleaning efficiency due to optimal contact of the tungsten carbide blade
- Long service life due to the use of highly wear-resistant carbide
- Protection of the carrier body due to run-off aprons at the segments
- Easy to fit and adjust
- Low maintenance

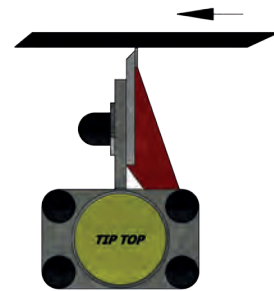

Technical Data

Conveyor Belt Width [mm]	Weight [kg]	A [mm]	B [mm]	C [mm]
500	34.1	480	720 – 1,315	1,500
650	35.8	600	840 – 1,1465	1,650
800	48.1	720	960 – 1,500	1,700
1,000	52.1	960	1,200 – 1,750	2,000
1,200	86.8	1,080	1,330 – 2,370	2,700
1,400	91.2	1,200	1,450 – 2,570	2,900
1,600	152.9	1,440	1,700 – 2,696	3,100
1,800	162.9	1,680	1,900 – 2,896	3,300
2,000	182.7	1,800	2,100 – 2,896	3,500
2,200	185.5	2,040	2,300 – 3,146	3,750
2,400	194.3	2,280	2,500 – 3,396	4,000
2,600	205.0	2,520	2,700 – 3,596	4,200

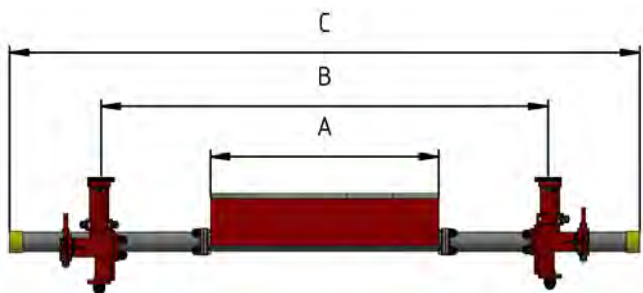

REMACLEAN HM-U3

U-Series – for belt return side applications

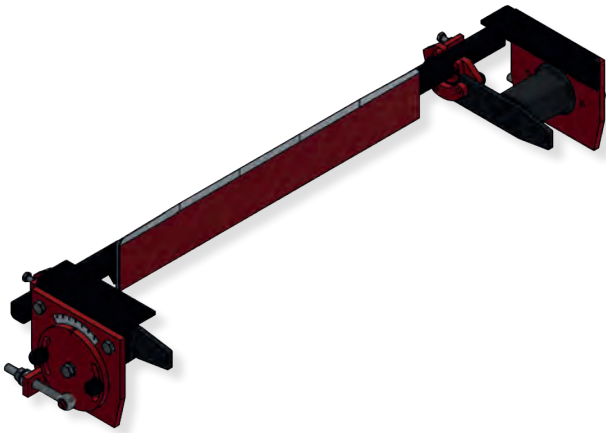

The **REMACLEAN HM-U3** system is an effective combination of the full-length **REMACLEAN HML** carbide bar and the precise **INNOVATION** tension unit. **REMACLEAN HM-U3** can be used for speeds up to 4.0 m/s and ensures effective cleaning that is gentle on the conveyor belt.

Benefits

- High cleaning efficiency
- Long service life due to the use of highly wear-resistant carbide
- Easy mounting and accurate adjustment on both sides
- Low maintenance
- For belt widths from 400 – 1,400 mm

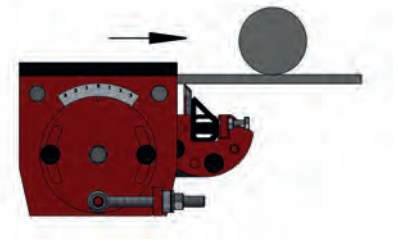

Technical Data

Conveyor Belt Width [mm]	Weight [kg]	A [mm]	B [mm]	C [mm]	F [mm]	G [mm]	H [mm]	I [mm]	J [mm]	K [mm]
400	19.1	360	600 – 800	720						
500	20.4	480	700 – 900	840	186	178	138	10	158	264
650	21.6	600	850 – 1,050	960						
800	22.9	720	1,050 – 1,250	1,080						
1,000	36.5	960	1,250 – 1,450	1,360	237	200	160	20	180	335
1,200	60.3	1,080	1,500 – 1,700	1,480	307	240	200	35	220	405
1,400	64.2	1,320	1,740 – 1,940	1,720						

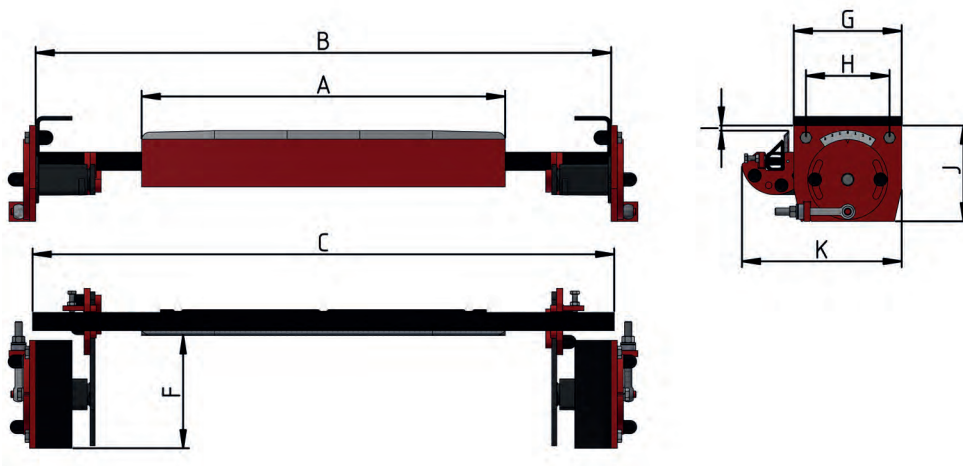

REMACLEAN HM-U7

U-Series – for belt return side applications

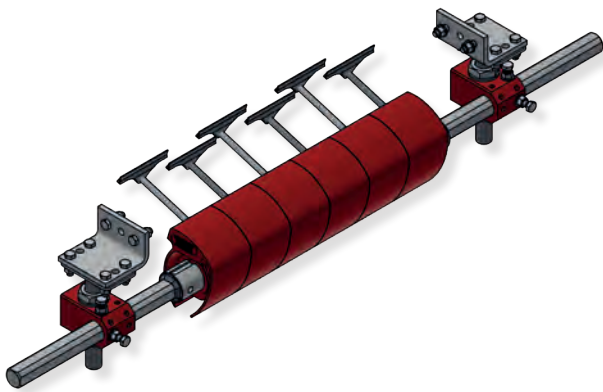

The cleaning system **REMACLEAN HM-U7** is suitable for speeds up to 4.0 m/s. Thanks to the effective combination of carbides embedded in polyurethane, optimum adaptation to the conveyor belt surface is ensured. The tungsten carbide blades can be rotated on their own axis and thus provide gentle cleaning of the conveyor belt.

Benefits

- Optimal adjustment of the carbide blades to the conveyor belt surface – thanks to rotatable mounting in the polyurethane base
- Long service life due to the use of highly wear-resistant carbide
- Toolless fastening of the segments thanks to quick-release fastener
- For belt widths from 400 – 1,400 mm

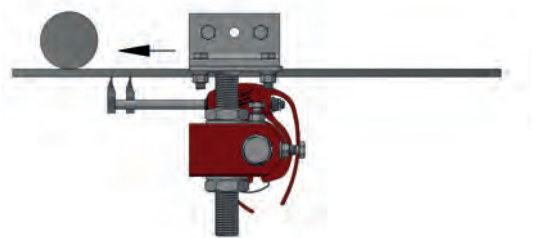

Technical Data

Conveyor Belt Width [mm]	Weight [kg]	A [mm]	B [mm]	C [mm]	Number of Carbide Blades
400	31.7	320	530 – 1,110	1,190	3
500	34.8	420	590 – 1,230	1,300	4
650	40.3	620	770 – 1,410	1,480	6
800	44.9	720	920 – 1,660	1,730	7
1,000	51.2	920	1,140 – 1,880	1,950	9
1,200	57.4	1,120	1,360 – 2,100	2,170	11
1,400	63.6	1,320	1,580 – 2,310	2,390	13

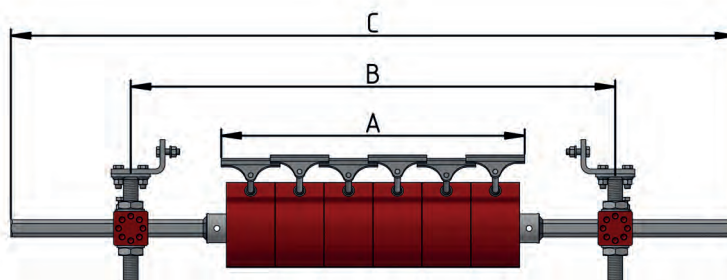
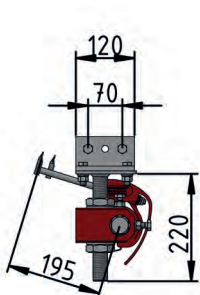

REMACLEAN HM-U8

U-Series – for belt return side applications

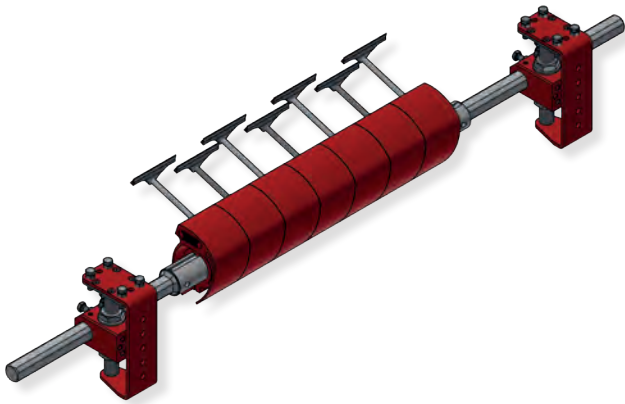

The cleaning system **REMACLEAN HM-U8** is suitable for speeds up to 6.5 m/s. Thanks to the effective combination of carbides embedded in polyurethane, optimum adaptation to the conveyor belt surface is ensured. The tungsten carbide blades can be rotated on their own axis and thus provide gentle cleaning of the conveyor belt.

Benefits

- Optimal adjustment of the carbide blades to the conveyor belt surface – thanks to rotatable mounting in the polyurethane base
- Long service life due to the use of highly wear-resistant carbide
- Segments bolted to the system support
- For belt widths from 800 – 2,000 mm

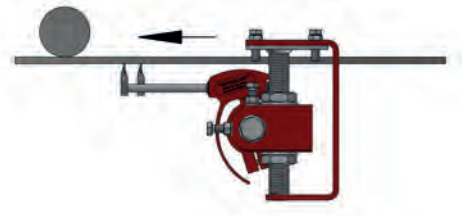

Technical Data

Conveyor Belt Width [mm]	Weight [kg]	A [mm]	B [mm]	C [mm]	Number of Carbide Blades
800	46.5	720	920 – 1,660	1,730	7
1,000	52.9	920	1,140 – 1,880	1,950	9
1,200	59.2	1,120	1,360 – 2,100	2,170	11
1,400	65.6	1,320	1,580 – 2,310	2,390	13
1,600	71.9	1,520	1,800 – 2,530	2,610	15
1,800	78.3	1,720	2,020 – 2,750	2,830	17
2,000	84.3	1,920	2,220 – 2,950	3,030	19

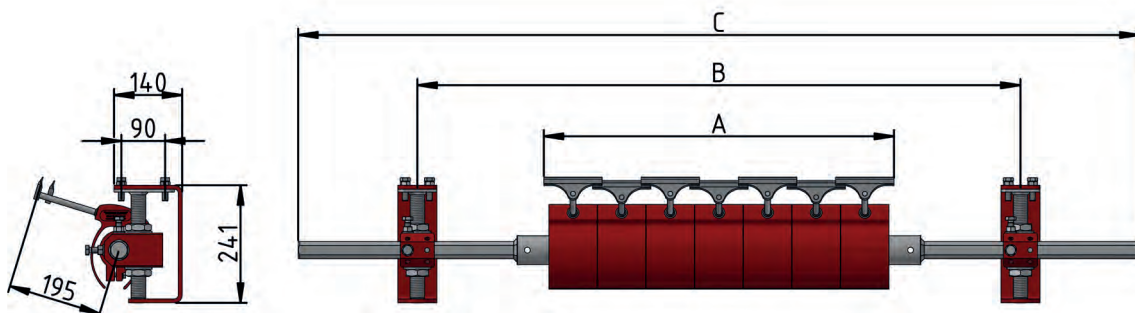

REMACLEAN HM-U9

U-Series – for belt return side applications

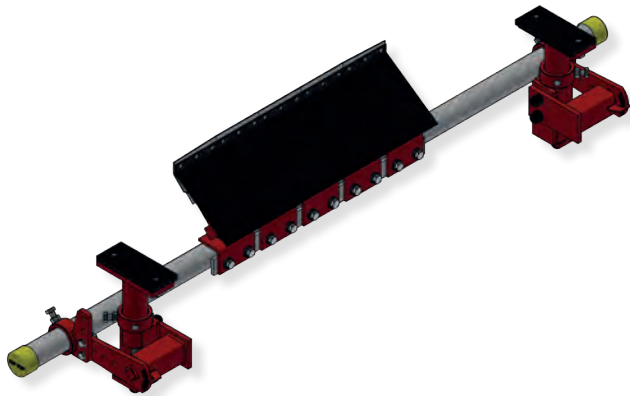

The REMACLEAN HM-U9 system is suitable for effective and gentle cleaning of conveyor belts up to 6.5 m/s. The individually flexible carbide blades adapt perfectly to the conveyor belt surface and can be easily adjusted thanks to a torsion spindle tensioning unit.

Benefits

- Optimal adjustment to the conveyor belt surface
- Long service life due to the use of highly wear-resistant carbide
- Protection of the system support by PE or VA drainage apron
- For belt widths from 650 – 2,000 mm

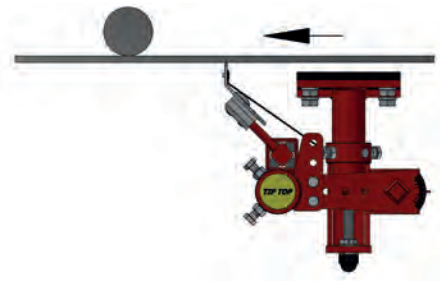

Technical Data

Conveyor Belt Width [mm]	Weight [kg]	A [mm]	B [mm]	C [mm]	D [mm]	F [mm]	G [mm]	H [mm]	I [mm]	J [mm]
650	42.6	600	725 – 1,390	1,650	51	103		85		
800	57.4	720	870 – 1,430	1,750	60,3	135	70	122	120	M16
1,000	65.1	960	1,110 – 1,680	2,000						
1,200	97.3	1,080	1,230 – 1,800	2,200	76,1	165		170		
1,400	103.1	1,200	1,350 – 2,000	2,400						
1,600	178.4	1,440	1,660 – 2,540	3,000	101,6	192	100	190	150	M20
1,800	192.6	1,680	1,900 – 2,840	3,300						
2,000	219.6	1,800	2,020 – 2,930	3,600		300				

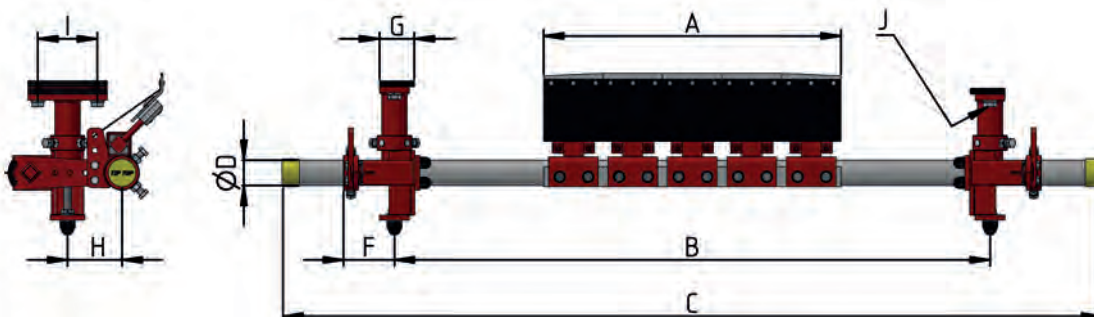

REMACLEAN HM-U10

U-Series – for belt return side applications

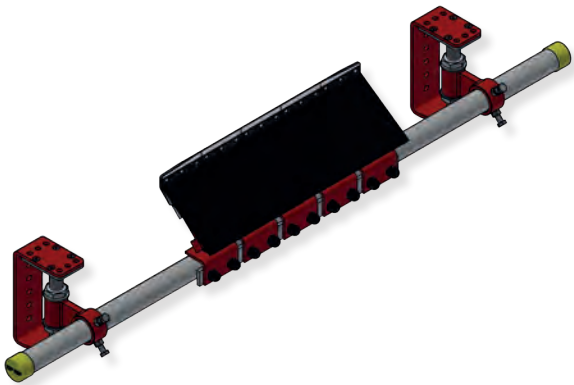

The REMACLEAN HM-U10 cleaning system is suitable for speeds of up to 6.5 m/s. Thanks to the individually movable tungsten carbide blades, optimum adaptation to the conveyor belt surface and thus effective cleaning that is gentle on the conveyor belt is guaranteed.

Benefits

- Optimal adjustment to the conveyor belt surface
- Long service life due to the use of highly wear-resistant carbide
- Easy adjustment of contact pressure by means of spindle clamping device
- For belt widths from 400 – 2,200 mm

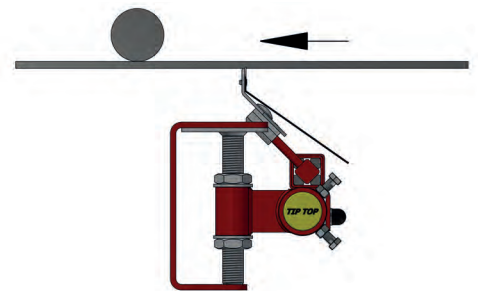

Technical Data

Conveyor Belt Width [mm]	Weight [kg]	A [mm]	B [mm]	C [mm]	D [mm]	Number of Carbide Blades
400	27.2	360	460 – 1,250	1,400	51	3
500	30.7	480	560 – 1,350	1,500		4
650	34.4	600	680 – 1,500	1,650		5
800	41.8	720	800 – 1,600	1,750	60,3	6
1,000	49.6	960	1,040 – 1,850	2,000		8
1,200	70.7	1,080	1,160 – 2,050	2,200	76,1	9
1,400	76.5	1,200	1,280 – 2,250	2,400		10
1,600	126.3	1,440	1,520 – 2,950	3,000	101,6	12
1,800	140.3	1,680	1,760 – 3,150	3,300		14
2,000	150.7	1,800	1,880 – 3,350	3,600		15
2,200	161.3	2,040	2,020 – 3,600	3,750		17

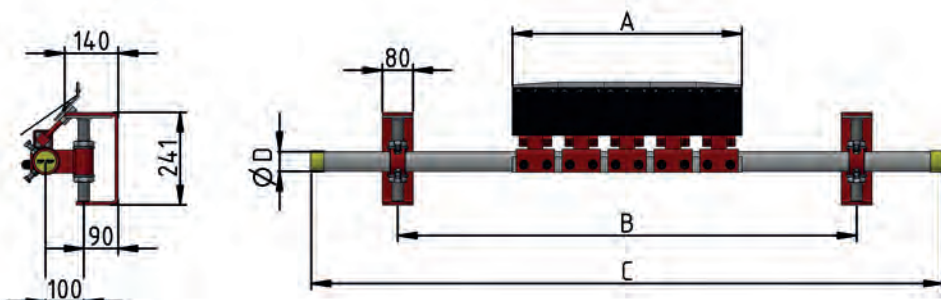

REMACLEAN HM-U10 S

U-Series – for belt return side applications

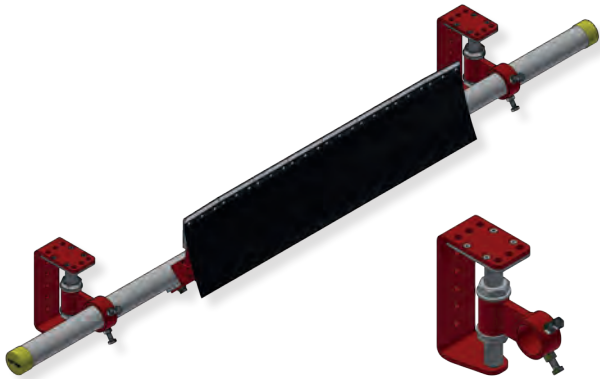

This system is suitable for cleaning the conveyor belt in the return side of the belt for speeds up to 6.5 m/s. The segments of the **REMACLEAN HM-U10 S** carbide blade perfectly adjust to the belt, thus providing an effective and belt-friendly cleaning. The design of the carbide blade with its anti-caking coating guarantees extended service life and high reliability. Precise pre-tensioning and subsequent control is ensured thanks to the spindle-type tension unit.

Benefits

- High cleaning efficiency due to optimal contact of the tungsten carbide blade
- Long service life due to the use of highly wear-resistant carbide
- Protection of the carrier body due to run-off aprons at the segments
- Easy to fit and adjust
- Low maintenance

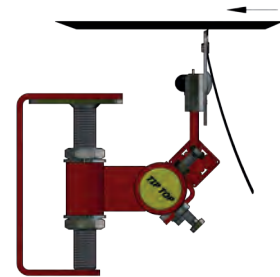

Technical Data

Conveyor Belt Width [mm]	Weight [kg]	A [mm]	B [mm]	C [mm]
400	27.2	360	460 – 1,250	1,400
500	30.7	480	560 – 1,350	1,500
650	34.4	600	680 – 1,500	1,650
800	41.8	720	800 – 1,600	1,750
1,000	49.6	960	1,200 – 1,750	2,000
1,200	70.7	1,080	1,330 – 2,370	2,700
1,400	76.5	1,200	1,450 – 2,570	2,900
1,600	126.3	1,440	1,700 – 2,696	3,100
1,800	140.3	1,680	1,900 – 2,896	3,300
2,000	150.7	1,800	2,100 – 2,896	3,500
2,200	161.3	2,040	2,300 – 3,146	3,750
2,400	164.1	2,160	2,500 – 3,396	4,000
2,600	175.9	2,400	2,700 – 3,596	4,200

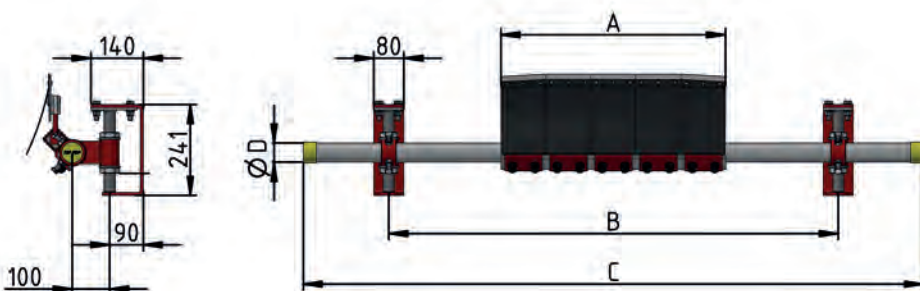

REMACLEAN HM-U11 R

U-Series – for belt return side applications

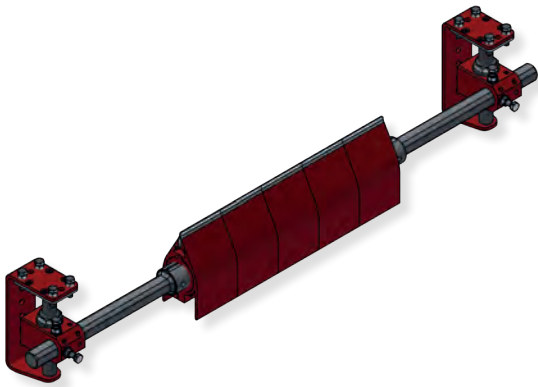

The REMACLEAN HM-U11R cleaning system is specially designed for use in reverse operation. The effective combination of polyurethane and carbide ensures effective cleaning that is gentle on the conveyor belt. The carbide segments, which are individually mounted in polyurethane, ensure optimum adaptation to the conveyor belt surface.

Benefits

- Optimal adjustment to the conveyor belt surface
- Easy adjustment of contact pressure thanks to spindle clamping device
- Developed for reverse operation
- Long service life due to the use of highly wear-resistant carbide
- For belt widths from 400 – 2,000 mm
- Belt speeds:
HM-U11R-70 up to 3.5 m/s
HM-U11R-85 up to 6.5 m/s

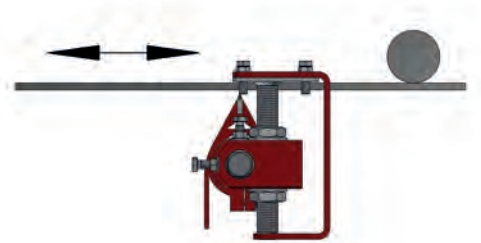

Technical Data

Conveyor Belt Width [mm]	Weight [kg]	A [mm]	B [mm]	C [mm]	Number of Segments
400	32.9	360	490 – 1,110	1,190	3
500	36.1	480	590 – 1,210	1,300	4
650	40.4	600	770 – 1,300	1,480	5
800	45.2	720	920 – 1,650	1,730	6
1,000	51.5	960	1,140 – 1,870	1,950	8
1,200	56.5	1,080	1,360 – 2,090	2,170	9
1,400	62.9	1,320	1,580 – 2,310	2,390	11
1,600	69.3	1,560	1,800 – 2,530	2,610	13
1,800	74.3	1,680	2,020 – 2,750	2,830	14
2,000	80.3	1,920	2,220 – 2,950	3,030	16

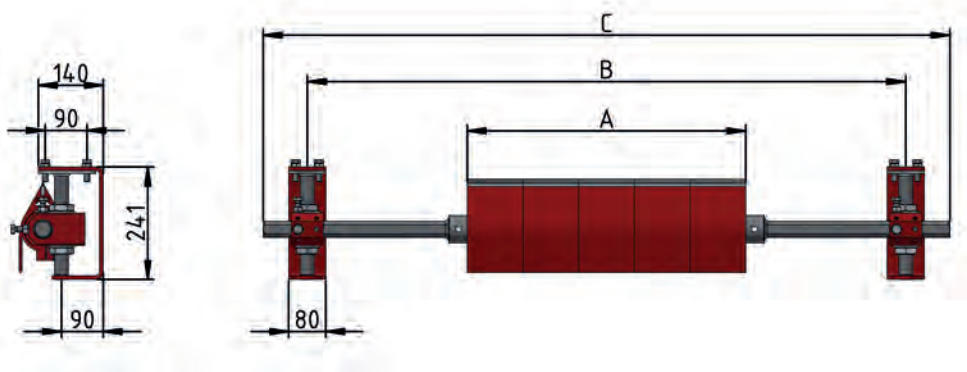

REMACLEAN HM-U500

U-Series – for belt return side applications

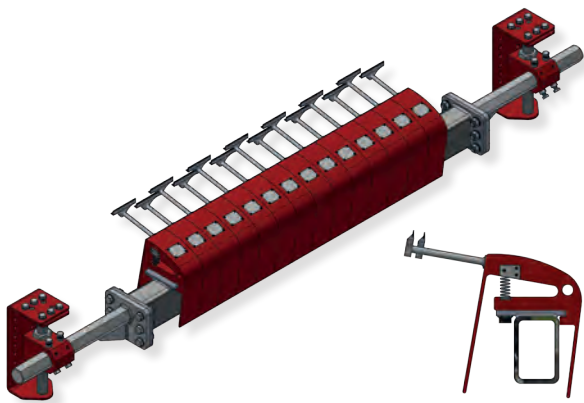

REMACLEAN HM-U500 is a universal system suitable for different types of material. The solid design of the support tube, where the individual segments are elastically mounted and the spindle-type tension unit, enable the usage of the system up to a belt speed of 10 m/s. The polyurethane-based carbide blades optimally adjust to the belt surface in its total length and guarantee an effective and belt-friendly cleaning.

Benefits

- High cleaning efficiency due to flexible mounting of the carbide segments
- Long service life due to the use of highly wear-resistant carbide
- Skirts on the back of the PUR-segments protect the support tube
- Consistent and optimal contact pressure towards the conveyor belt

Technical Data

Conveyor Belt Width [mm]	Weight [kg]	A [mm]	B [mm]	C [mm]	D [mm]	E [mm]	Number of PUR-Segments
1,400	239	1,320	1,790	2,990	160	150 x 100	13
1,600	244	1,420	1,790	2,990	160	150 x 100	14
1,800	257	1,520	1,990	3,190	160	150 x 100	15
2,000	275	1,720	2,190	3,390	160	150 x 100	17
2,200	283	1,720	2,390	3,590	160	150 x 100	17
2,200	293	1,920	2,390	3,590	160	150 x 100	19
2,400	300	1,920	2,590	3,790	160	150 x 100	19
2,600	319	2,120	2,790	3,990	160	150 x 100	21
2,800	326	2,120	2,990	4,190	160	150 x 100	21
2,800	337 (348)	2,320 (2,520)	2,990	4,190	160	150 x 100	23 (25)
3,000	359 (371)	2,520 (2,720)	3,290	4,490	160	150 x 100	25 (27)

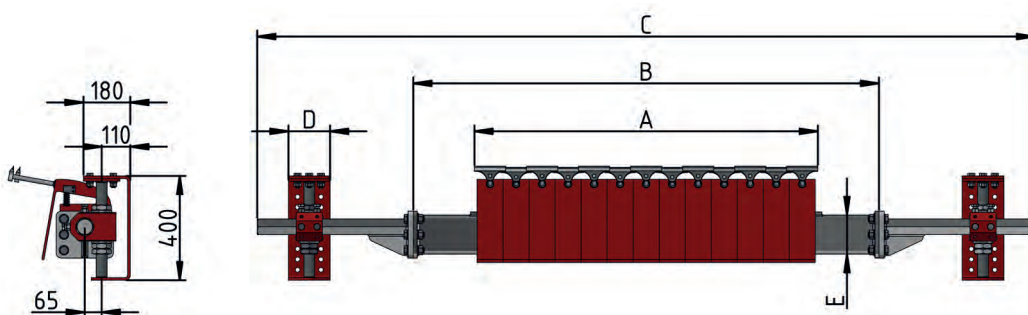

REMACLEAN HM-F2 F-Series – for use on the pulley

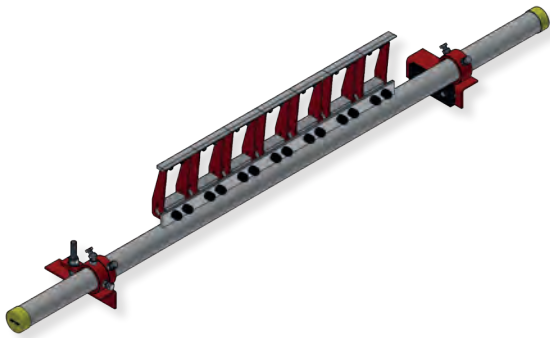

REMACLEAN HM-F2 PUR systems are suitable for belt friendly cleaning at speeds up to 4.5 m/s. The individually flexible segments are fitted with highly abrasion-resistant carbides and ensure ideal adjustment to the conveyor belt surface.

Benefits

- High cleaning efficiency due to optimal contact of the individual carbide segments
- Long service life due to the use of highly wear-resistant carbide
- Easy mounting, adjustment and maintenance of the system
- Easy adjustment of contact pressure thanks to spindle clamping device
- For belt widths from 400 – 2,000 mm

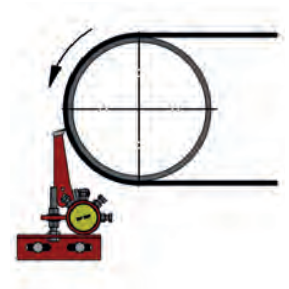

Technical Data

Conveyor Belt Width [mm]	Weight [kg]	A [mm]	B [mm]	C [mm]
400	17.8	360	500 – 1,260	1,400
500	19.9	480	620 – 1,360	1,500
650	22.2	600	740 – 1,510	1,650
800	28.3	720	860 – 1,610	1,750
1,000	33.3	960	1,100 – 1,860	2,000
1,200	53.6	1,080	1,304 – 1,976	2,200
1,400	57.4	1,200	1,424 – 2,176	2,400
1,600	98.1	1,440	1,670 – 2,870	3,100
1,800	105.8	1,680	1,910 – 3,070	3,300
2,000	111.9	1,800	2,030 – 3,270	3,500

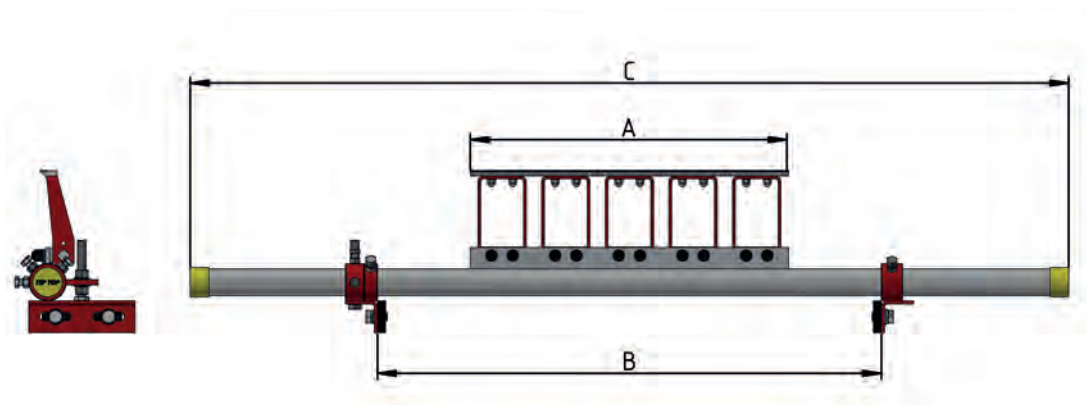

REMACLEAN HM-F2 PUR

F-Series – for use on the pulley

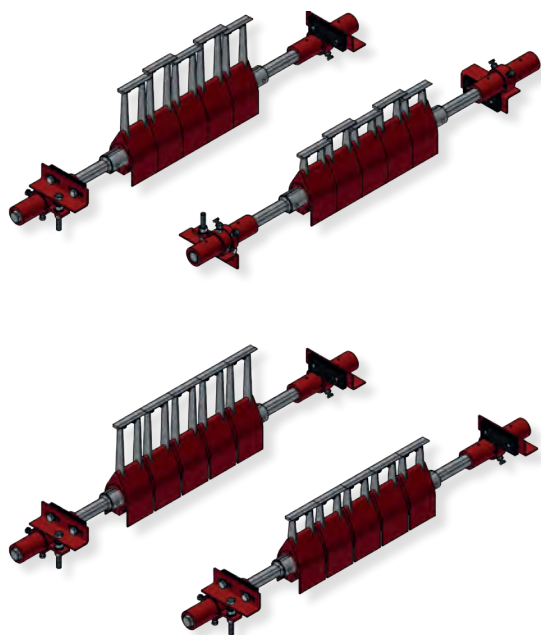

REMACLEAN HM-F2 PUR systems are suitable for belt friendly cleaning at speeds up to 4.5 m/s. The individual segments are an optimal combination of the advantages of polyurethane and carbide. The flexible segments ensure optimum adaptation to the conveyor belt surface.

Benefits

- High cleaning efficiency due to optimal contact of the individual segments
- Long service life due to the use of highly wear-resistant carbide
- Easy adjustment of contact pressure thanks to lever clamping device
- Protection of the system carrier thanks to integrated drainage aprons
- Easy mounting, adjustment and maintenance of the system
- For belt widths from 500 – 2,000 mm

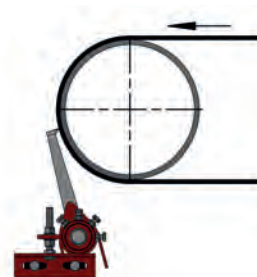

Technical Data

Conveyor Belt Width [mm]	Weight [kg]		A [mm]	B [mm]	C [mm]	D [mm]
	SL	LL				
500	34.7	–	450	500	560 – 1,160	1,300
650	39.3	40.3	560	680	730 – 1,340	1,480
800	44.1	45.4	670	830	880 – 1,590	1,730
1,000	50.8	52.5	890	1,050	1,080 – 1,790	1,950
1,200	56.0	57.8	1,000	1,270	1,300 – 2,020	2,170
1,400	61.2	63.2	1,220	1,490	1,520 – 2,240	2,390
1,600	67.9	70.3	1,440	1,710	1,740 – 2,460	2,610
1,800	74.6	77.4	1,660	1,930	1,960 – 2,680	2,830
2,000	79.4	82.5	1,770	2,130	2,160 – 2,880	3,030

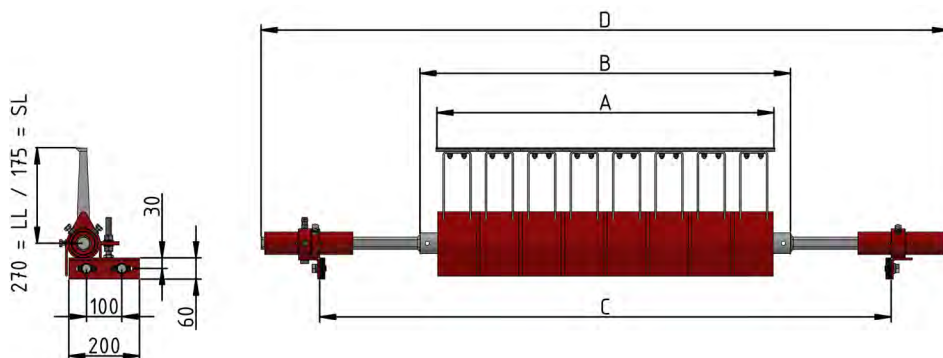

REMACLEAN PUR-F3

F-Series – for use on the pulley

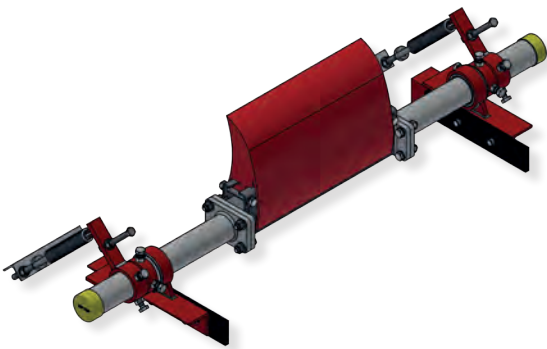

The REMACLEAN PUR-F3 system is suitable for speeds up to 4.0 m/s and drum diameters up to 800 mm. The highly abrasion-resistant and individually movable PUR segments ensure optimum adaptation to the conveyor belt surface as well as effective cleaning that is gentle on the conveyor belt.

Benefits

- Polyurethane scrapers available as segments or as full-length mono bar
- Long service life due to the use of highly abrasion-resistant polyurethane
- Simple adjustment thanks to the tension spring of the lever clamping device
- For belt widths up to 2,200 mm
- For drum diameters up to 800 mm
- Different PUR variants available depending on the area of application

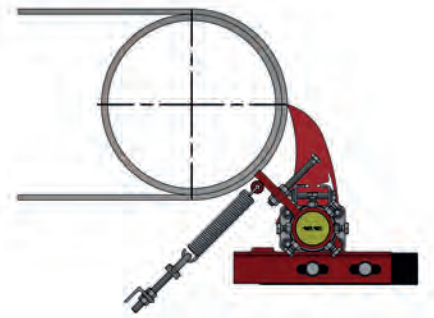

Technical Data

Conveyor Belt Width [mm]	Weight [kg]	A [mm]	B [mm]	C [mm]
500	34.6	400	550 – 1,050	1,340
650	40.1	600	700 – 1,200	1,540
800	42.9	700	850 – 1,350	1,640
1,000	57.4	900	1,050 – 2,300	2,600
1,200	63.1	1,100	1,250 – 2,500	2,800
1,400	68.5	1,300	1,450 – 2,700	3,000
1,600	74.1	1,500	1,650 – 2,900	3,200
1,800	79.5	1,700	1,850 – 3,100	3,400
2,000	85.0	1,900	2,050 – 3,300	3,600
2,200	90.5	2,100	2,250 – 3,500	3,800

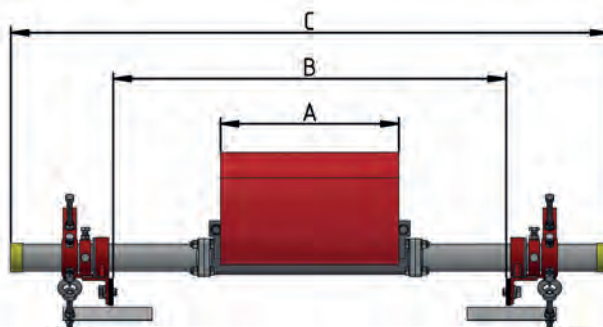
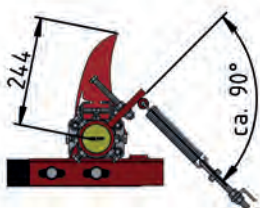

REMACLEAN PUR-F4

F-Series – for use on the pulley

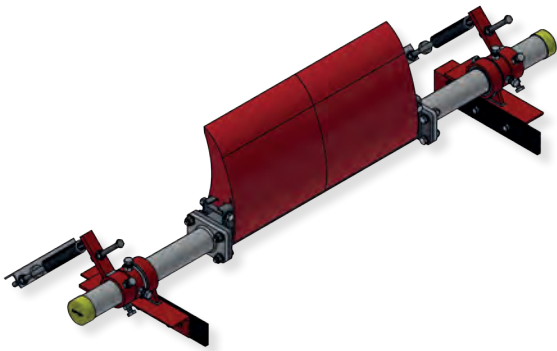

The system **REMACLEAN PUR-F4** is suitable for speeds up to 4.0 m/s and drum diameters up to 1,000 mm. The highly abrasion-resistant and individually movable PUR segments ensure optimum adaptation to the conveyor belt surface as well as effective cleaning that is gentle on the conveyor belt.

Benefits

- Polyurethane scrapers available as segments or as full-length mono bar
- Long service life due to the use of highly abrasion-resistant polyurethane
- Simple adjustment thanks to the tension spring of the lever clamping device
- For belt widths up to 2,400 mm
- For drum diameters up to 1,000 mm
- Different PUR variants available depending on the area of application

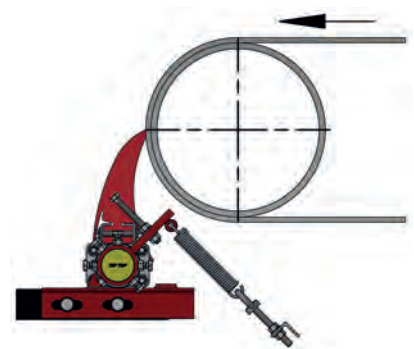

Technical Data

Conveyor Belt Width [mm]	Weight [kg]	A [mm]	B [mm]	C [mm]
500	35.2	400	550 – 1,050	1,340
650	41.0	600	700 – 1,200	1,540
800	43.9	700	850 – 1,350	1,640
1,000	58.7	900	1,050 – 2,300	2,600
1,200	64.7	1,100	1,250 – 2,500	2,800
1,400	70.5	1,300	1,450 – 2,700	3,000
1,600	76.3	1,500	1,650 – 2,900	3,200
1,800	81.9	1,700	1,850 – 3,100	3,400
2,000	87.8	1,900	2,050 – 3,300	3,600
2,200	93.6	2,100	2,250 – 3,500	3,800

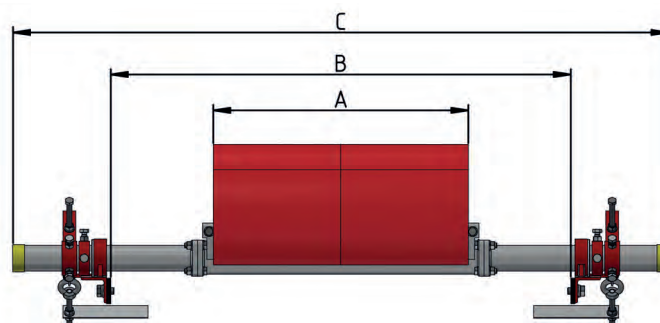
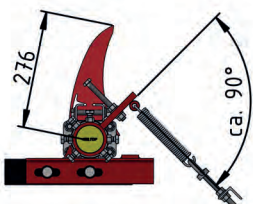

REMACLEAN PUR-F4 HD

F-Series – for use on the pulley

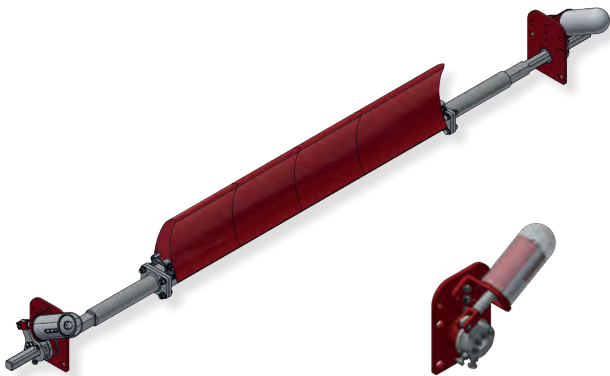

This system is suitable for cleaning the conveyor carrying side at the pulley for belt speeds up to 6 m/s. The individual segments of **REMACLEAN PUR-F4 HD** are firmly connected to the system carrier and at the same time flexible, so that the segments can optimally adjust to the conveyor belt surface. This allows effective and gentle cleaning. Precise pre-tensioning of the entire scraper blade is ensured thanks to a lever clamping device on one or both sides.

Benefits

- High cleaning efficiency due to optimal contact of the individual PUR segments
- Long service life due to the use of highly wear-resistant polyurethane
- Also suitable for reverse operation
- Easy to fit and adjust
- Low maintenance

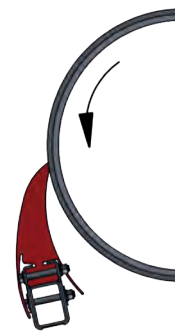

Technical Data

Conveyor Belt Width [mm]	Weight [kg]	A [mm]	B [mm]	C [mm]	D [mm]
800	63.2	700	774	1,600 – 2,020	2,198
1,000	68.9	900	974	1,800 – 2,220	2,398
1,200	74.9	1,100	1,174	2,000 – 2,420	2,598
1,400	80.7	1,300	1,374	2,200 – 2,620	2,798
1,600	86.5	1,500	1,574	2,400 – 2,820	2,998
1,800	92.2	1,700	1,774	2,600 – 3,020	3,198
2,000	98.0	1,900	1,974	2,800 – 3,220	3,398
2,200	103.9	2,100	2,174	3,000 – 3,420	3,598
2,400	109.0	2,300	2,374	3,200 – 3,620	3,798
2,600	115.0	2,500	2,574	3,400 – 3,820	3,998

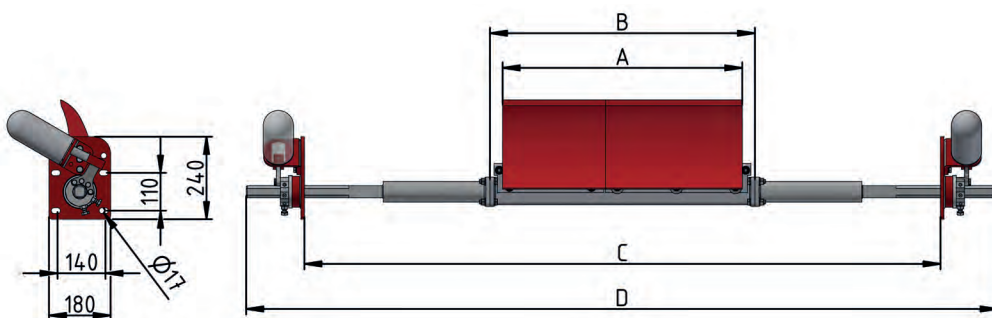

REMACLEAN PUR-F5

F-Series – for use on the pulley

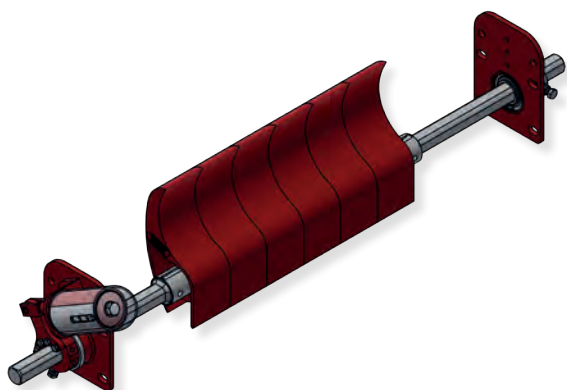

The **REMACLEAN PUR-F5** system is suitable for speeds up to 4.0 m/s and drum diameters up to 800 mm. The highly abrasion-resistant and individually movable PUR segments ensure optimum adaptation to the conveyor belt surface as well as effective cleaning that is gentle on the conveyor belt.

Benefits

- Optimum adaptation to the conveyor belt surface thanks to individually movable PUR segments
- Long service life due to the use of highly abrasion-resistant polyurethane
- Easy adjustment of contact pressure due to lever clamping device
- For belt widths from 500 – 1,600 mm
- For drum diameters from 200 – 800 mm

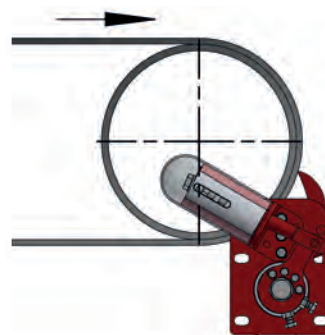

Technical Data

Conveyor Belt Width [mm]	Weight [kg]	A [mm]	B [mm]	C [mm]
400	31.1	300	410 – 1,050	1,190
500	34.1	400	520 – 1,160	1,300
650	39.3	600	700 – 1,340	1,480
800	44.5	700	850 – 1,590	1,730
1,000	49.8	900	1,070 – 1,810	1,950
1,200	55.8	1,100	1,290 – 2,030	2,170
1,400	61.7	1,300	1,510 – 2,250	2,390
1,600	67.7	1,500	1,740 – 2,440	2,610

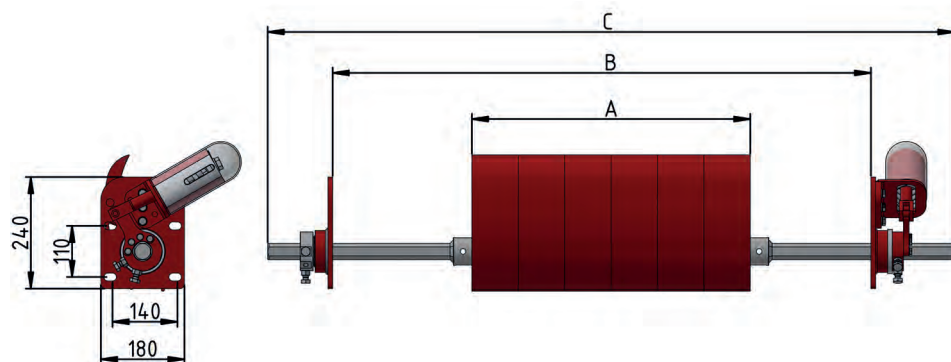

REMACLEAN PUR-F6

F-Series – for use on the pulley

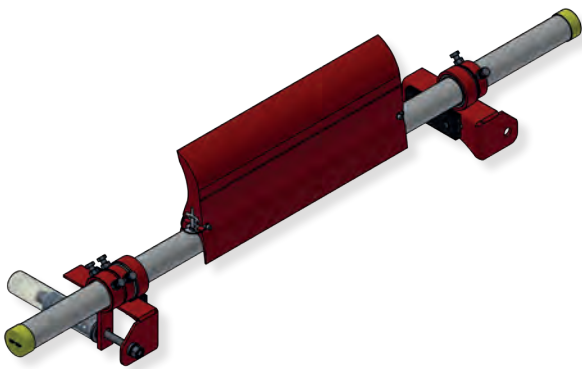

The **REMACLEAN PUR-F6** cleaning system is suitable for belt speeds up to 4.0 m/s. The polyurethane scraper bar includes a rail for easy mounting on the system carrier. It adapts well to the surface of the conveyor belt and ensures effective cleaning that is gentle on the belt.

Benefits

- Continuous scraper bar made of highly abrasion-resistant polyurethane
- Easy maintenance and mounting due to integrated mounting rail
- Easy adjustment of contact pressure thanks to lever clamping device
- For drum diameters from 200 – 800 mm
- For belt widths from 500 – 1,600 mm

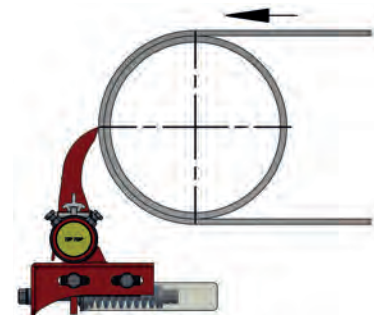

Technical Data

Conveyor Belt Width [mm]	A [mm] Standard (-200)	Weight [kg]	A [mm] Long (-50)	Weight [kg]	B [mm]	C [mm]
500	300	24.3	450	25,8	500 – 1,260	1,500
650	450	27.2	600	28,7	650 – 1,410	1,650
800	600	29.8	750	31,3	800 – 1,510	1,750
1,000	800	33.9	950	35,5	1,000 – 1,760	2,000
1,200	1,000	40.2	1,150	41,7	1,200 – 1,960	2,200
1,400	1,200	44.1	1,350	45,6	1,400 – 2,160	2,400
1,600	1,400	47.9	1,550	49,4	1,600 – 2,360	2,600

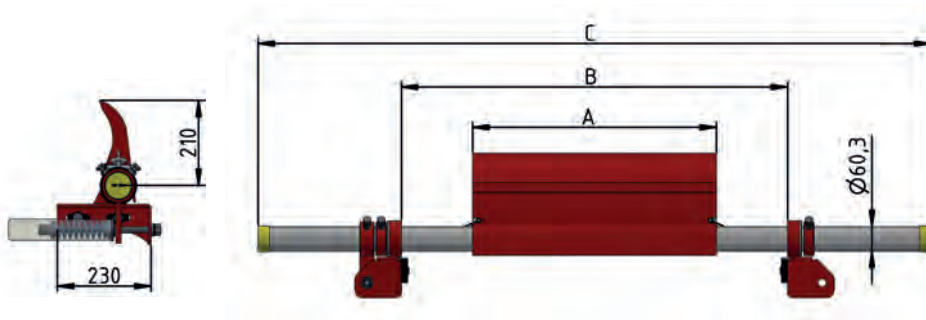

REMACLEAN PUR-F8 F-Series – for use on the pulley

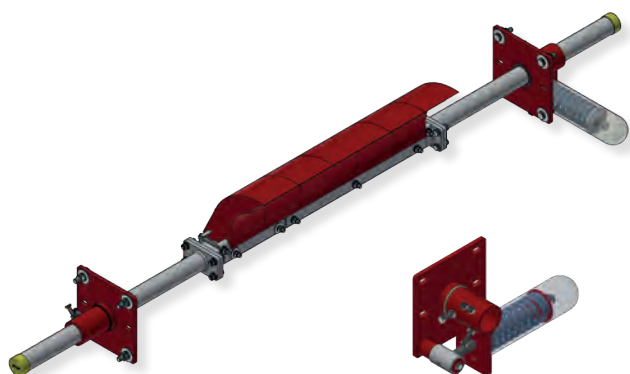

This system is suitable for cleaning the conveyor belt carrying side on pulleys from $\varnothing 500 - 1,800$ mm and for belt speeds up to 6 m/s. The individual segments of **REMACLEAN PUR-F8** are firmly connected to the system carrier and at the same time flexible, so that the segments can optimally adjust to the conveyor belt surface. This allows effective and gentle cleaning. Precise pre-tensioning of the entire scraper blade is ensured thanks to a lever clamping device on one or both sides.

Benefits

- High cleaning efficiency due to optimal contact of the individual PUR segments
- Long service life due to the use of highly wear-resistant polyurethane
- Also suitable for reverse operation
- Easy to fit and adjust
- Low maintenance

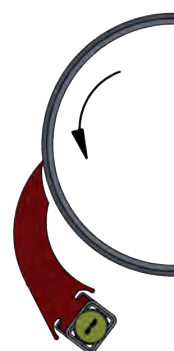

Technical Data

Conveyor Belt Width [mm]	Weight [kg]	A [mm]	B [mm]	C [mm]	D [mm]
650	57.7	570	694	720 – 1,220	1,558
800	64.3	730	854	880 – 1,380	1,718
1,000	80.8	910	1,034	1,160 – 2,310	1,898
1,200	87.5	1,070	1,194	1,320 – 2,470	2,058
1,400	102.7	1,250	1,374	1,500 – 2,650	2,238
1,600	112.7	1,480	1,604	1,730 – 2,280	2,468
1,800	119.6	1,640	1,764	1,890 – 3,040	2,628
2,000	141.6	1,870	1,994	2,120 – 3,270	2,858
2,200	149.5	2,030	2,154	2,280 – 3,430	3,018

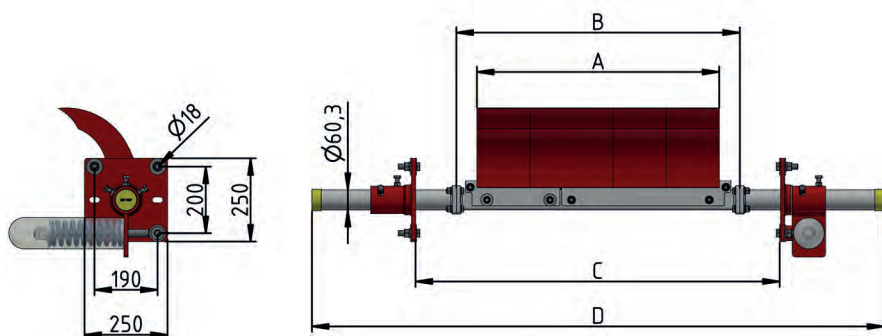

REMACLEAN PUR-F300

F-Series – for use on the pulley

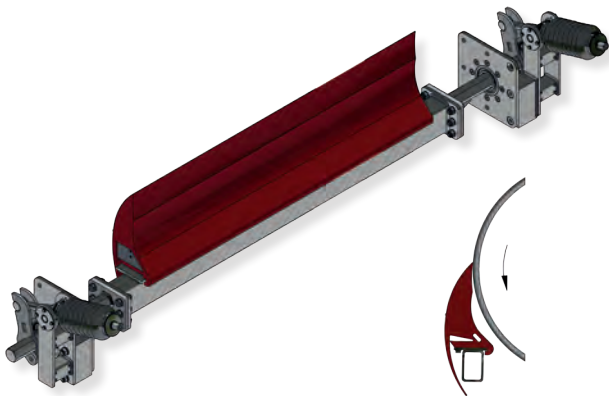

This system is suitable for pre-cleaning the conveyor belt load-bearing side at the head pulley for belt speeds up to 10 m/s and drum diameters of 630 mm and above. The individual polyurethane segments of **REMACLEAN PUR-F300** are firmly connected to the system carrier and at the same time flexible, so that the segments can optimally adjust to the conveyor belt surface. This allows effective and gentle cleaning. Precise pre-tensioning of the entire scraper blade is ensured thanks to a lever clamping device on one or both sides.

Benefits

- High cleaning efficiency due to optimal contact of the individual PUR segments
- Long service life due to the use of highly wear-resistant polyurethane
- Also suitable for reverse operation
- Suitable for heavy loads
- Low maintenance

Technical Data

Conveyor Belt Width [mm]	Weight [kg]	A [mm]	B [mm]	C [mm]	D [mm]	E [mm]
1,000	260.8	900	1,200	2,400	260	150 x 100
1,200	267.9	900	1,400	2,600	260	150 x 100
1,400	298.0	1,200	1,600	2,800	260	150 x 100
1,600	327.7	1,500	1,800	3,000	260	150 x 100
1,800	373.7	1,500	2,000	3,200	260	150 x 100
2,000	403.5	1,800	2,200	3,400	260	150 x 100
2,200	433.3	2,100	2,400	3,600	260	150 x 100
2,400	450.0	2,100	2,600	3,800	260	150 x 100

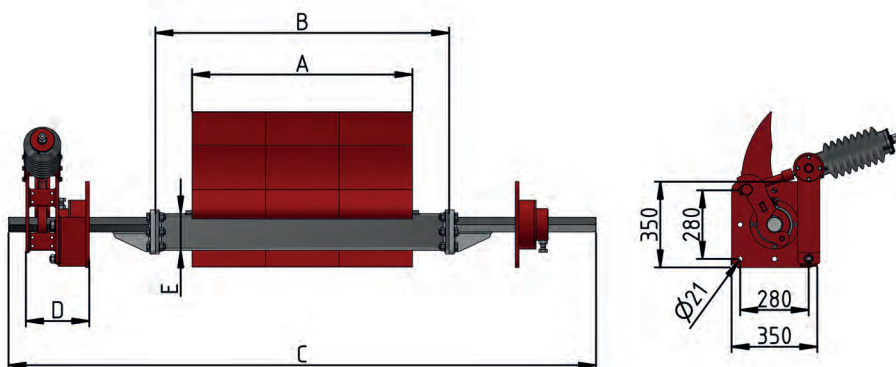

REMACLEAN PUR-F400 F-Series – for use on the pulley

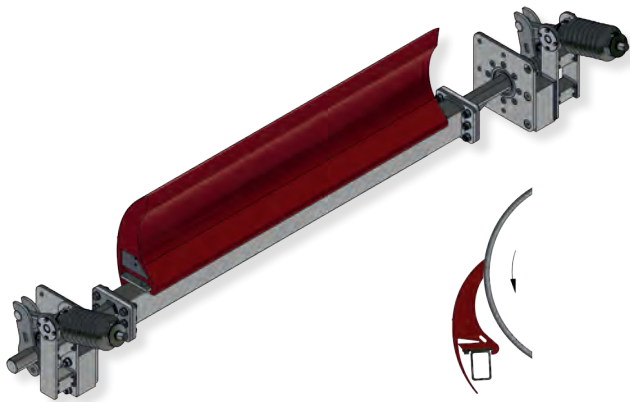

This system is suitable for pre-cleaning the conveyor belt load-bearing side at the head pulley for belt speeds up to 10 m/s and drum diameters of 1,000 mm and above. The individual polyurethane segments of **REMACLEAN PUR-F400** are firmly connected to the system carrier and at the same time flexible, so that the segments can optimally adjust to the conveyor belt surface. This allows effective and gentle cleaning. Precise pre-tensioning of the entire scraper blade with the PUR segments is ensured thanks to a lever clamping device on one or both sides.

Benefits

- High cleaning efficiency due to optimal contact of the individual PUR segments
- Long service life due to the use of highly wear-resistant polyurethane
- Also suitable for reverse operation
- Suitable for heavy loads
- Easy to fit and adjust
- Low maintenance

Technical Data

Conveyor Belt Width [mm]	Weight [kg]	A [mm]	B [mm]	C [mm]	D [mm]	E [mm]
1,000	266.8	900	1,200	2,400	260	150 x 100
1,200	273.8	900	1,400	2,600	260	150 x 100
1,400	305.9	1,200	1,600	2,800	260	150 x 100
1,600	307.4	1,500	1,800	3,000	260	150 x 100
1,800	349.9	1,500	2,000	3,200	260	150 x 100
2,000	415.5	1,800	2,200	3,400	260	150 x 100
2,200	447.3	2,100	2,400	3,600	260	150 x 100
2,400	460.0	2,100	2,600	3,800	260	150 x 100

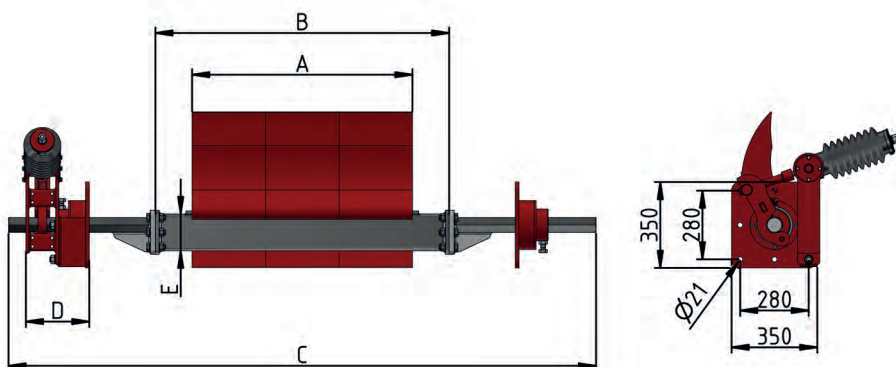

REMACLEAN PUR-F500

F-Series – for use on the pulley

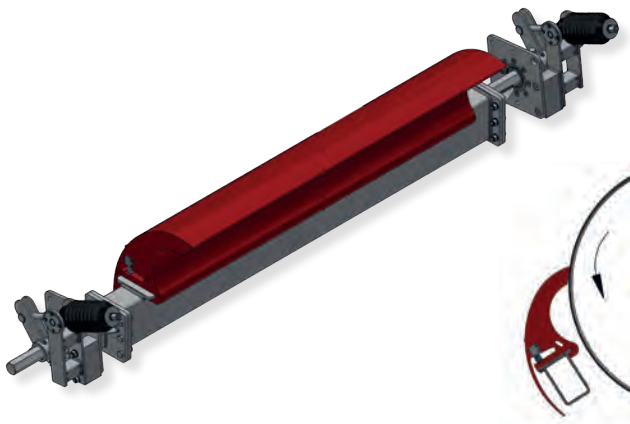

This system is suitable for pre-cleaning the conveyor belt load-bearing side at the head pulley for belt speeds up to 10 m/s. The individual polyurethane segments of **REMACLEAN PUR-F500** are firmly connected to the support tube and at the same time flexible, so that the segments can optimally adjust to the conveyor belt surface. This allows effective and belt-friendly cleaning.

Benefits

- High cleaning efficiency due to optimal adjustment of the PUR segments to the belt's surface
- Long service life due to the use of highly wear-resistant polyurethane
- Suitable for heavy loads
- Easy to fit and adjust
- Low maintenance

Technical Data

Conveyor Belt Width [mm]	Weight [kg]	A [mm]	B [mm]	C [mm]	D [mm]	E [mm]	Number of PUR-Segments
1,800	503	1,500	1,900	3,100	260	250 x 150	5
2,000	667	1,800	2,100	3,300	260	250 x 150	6
2,200	681	1,800	2,300	3,500	260	250 x 150	6
2,200	731	2,100	2,300	3,500	260	250 x 150	7
2,400	745	2,100	2,500	3,700	260	250 x 150	7
2,600	809	2,400	2,700	3,900	260	250 x 150	8
2,800	823	2,400	2,900	4,200	260	250 x 150	8
2,800	872	2,700	2,900	4,200	260	250 x 150	9
3,000	894	2,700	3,200	4,400	260	250 x 150	9

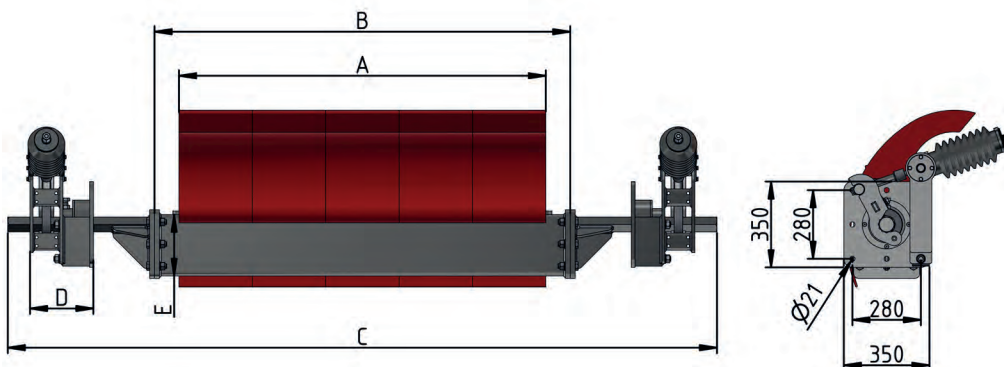

REMACLEAN RB-IGD

I-Series – for use on the inner belt

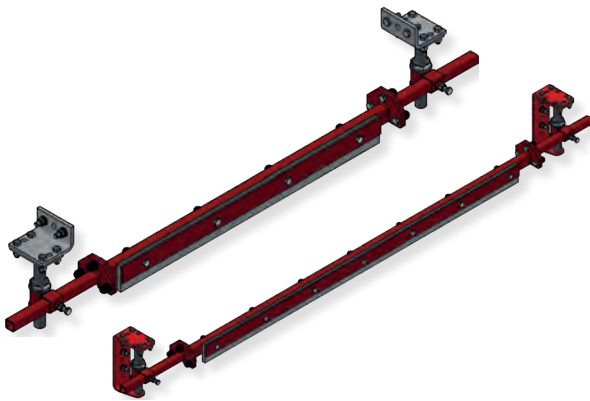

The effective **REMACLEAN RB-IGD** conveyor belt cleaning system is equipped with highly abrasion-resistant REMACLEAN CAB rubber to ensure gentle cleaning of the inner belt. The system ensures that no excess material is deposited on the conveyor system components.

Benefits

- Scraper bar made of REMACLEAN CAB for belt-friendly cleaning
- For belt speeds up to 3.5 m/s
- Easy adjustment thanks to spindle clamping device
- For belt widths from 400 – 2,000 mm
- Also available with PE scraper bar or in types ATEX and LOBA



Technical Data

Conveyor Belt Width [mm]	Weight [kg]	A [mm]	B [mm]	C [mm]
400	18.1	630	1,320	700
500	19.2	800	1,480	870
650	20.4	950	1,630	1,020
800	21.9	1,150	1,830	1,220
1,000	23.5	1,350	2,030	1,420
1,200	27.4	1,530	2,380	1,770
1,400	32.9	1,780	2,630	2,020
1,600	33.8	2,030	2,880	2,270
1,800	37.5	2,260	3,110	2,500
2,000	39.9	2,520	3,370	2,760

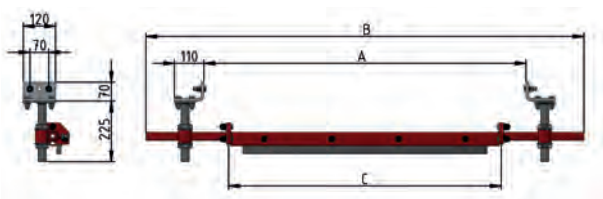

up to belt width 1,000

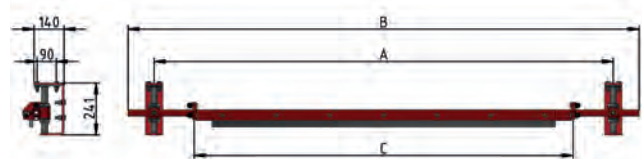

up to belt width 1,200

REMACLEAN IGD HD I-Series – for use on the inner belt

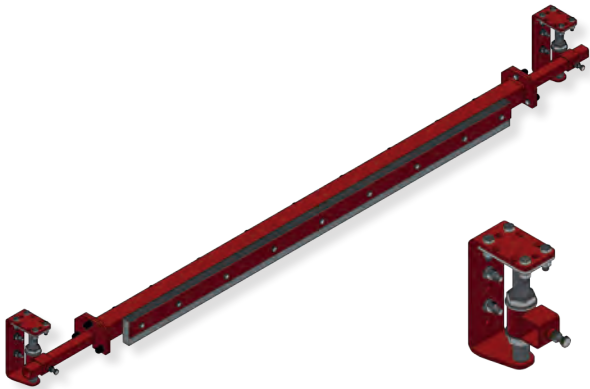

This system is suitable for use in the lower run for cleaning the inner side of the belt in large conveyor systems. The rubber scraper blade of the **REMACLEAN IGD HD** diagonal cleaner serves to protect the pulley from accumulating material.

Benefits

- Belt-friendly cleaning due to rubber scraper
- Optimal contact pressure due to spindle-type tension unit
- System support structure designed for heavy loads
- Easy to fit and adjust
- Low maintenance

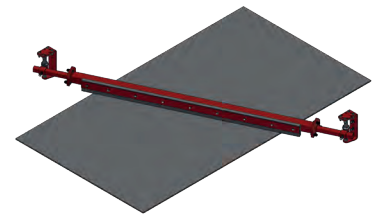

Technical Data

Conveyor Belt Width [mm]	Weight [kg]	A [mm]	B [mm]	C [mm]	D [mm]
1,000	42	1,400	1,515	1,645 – 2,080	2,135
1,200	46	1,600	1,765	1,895 – 2,330	2,385
1,400	49	1,800	2,015	2,145 – 2,580	2,635
1,600	53	2,000	2,265	2,395 – 2,830	2,885
1,800	56	2,200	2,515	2,645 – 3,080	3,135
2,000	60	2,400	2,765	2,895 – 3,330	3,385
2,200	63	2,600	3,015	3,145 – 3,580	3,635

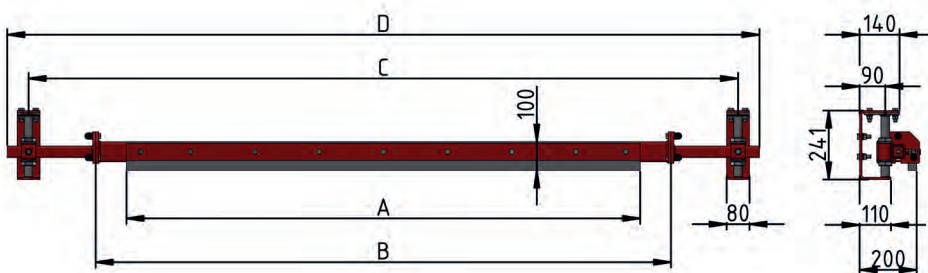

REMACLEAN RB-IGP-S I-Series – for use on the inner belt



The effective **REMACLEAN RB-IGP-S** conveyor belt cleaning system is equipped with highly abrasion-resistant PE scraper bars and thus ensures gentle cleaning of the inner belt. The system assures that no excess material is deposited on the conveyor system components.

Benefits

- Scraper bar made of highly abrasion-resistant PE for belt-friendly cleaning
- For belt speeds up to 4.0 m/s
- Easy adjustment due to inherent weight
- Easy mounting, adjustment and maintenance of the system
- For belt widths from 500 – 1,600 mm



Technical Data

Conveyor Belt Width [mm]	Weight [kg]	A [mm]	B [mm]	C [mm]
500/650	30.9	1,220	700	495
800	33.7	1,370	890	630
1,000	38.3	1,570	1,095	775
1,200	56.4	1,770	1,300	920
1,400	61.8	1,970	1,500	1,055
1,600	68.6	2,170	1,705	1,200
1,800	74.0	2,370	1,900	1,345

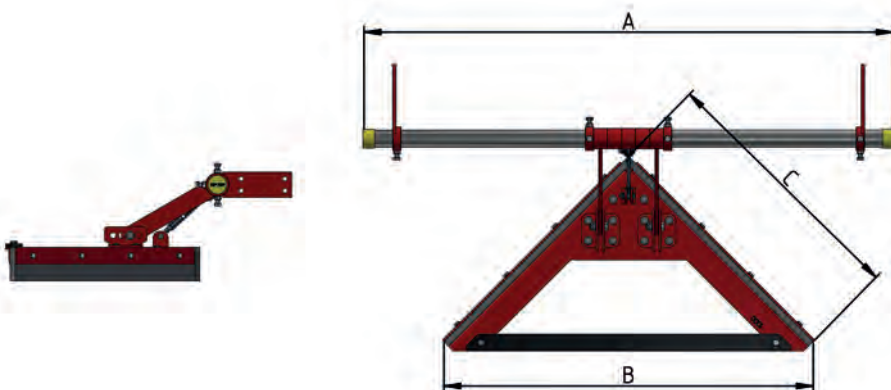

REMACLEAN RB-IGP-S HD

I-Series – for use on the inner belt



This system is suitable for use in the lower run for cleaning the inner side of the belt in large conveyor systems. The rubber scraper blade of the **REMACLEAN IGP-S HD** plough scraper serves to protect the pulley from accumulating material.

Benefits

- Belt-friendly cleaning due to rubber scraper
- No belt misalignment due to symmetrical design
- Auxiliary wheel mounted on scraper protects belt after rubber bar is worn out
- Easy to fit and adjust
- Low maintenance

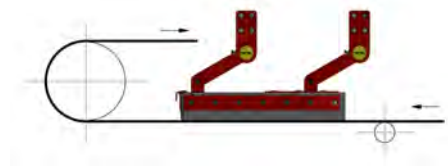

Technical Data

Conveyor Belt Width [mm]	Weight [kg]	A [mm]	B [mm]	C [mm]
1,200	175.7	1,300	680	2,700
1,400	187.7	1,530	790	2,900
1,600	200.0	1,725	890	3,100
1,800	212.4	1,985	1,020	3,300
2,000	373.5	2,285	1,180	3,500
2,200	392.6	2,495	1,285	3,700
2,400	410.9	2,700	1,390	3,900
2,600	429.5	2,915	1,495	4,100

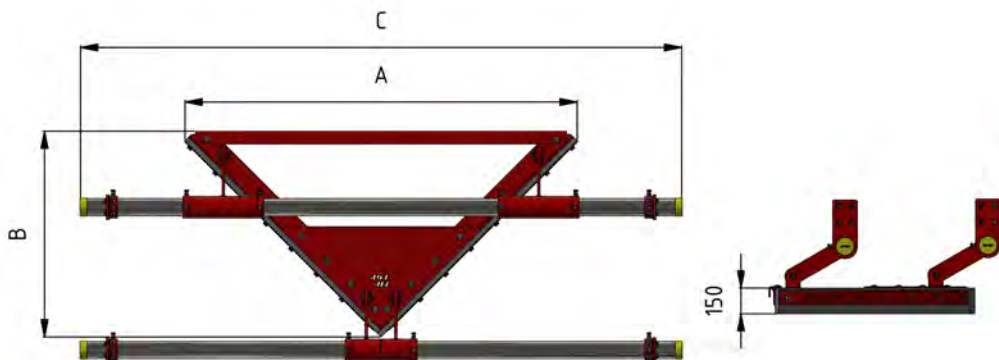

REMACLEAN SGB Belt cleaning brushes

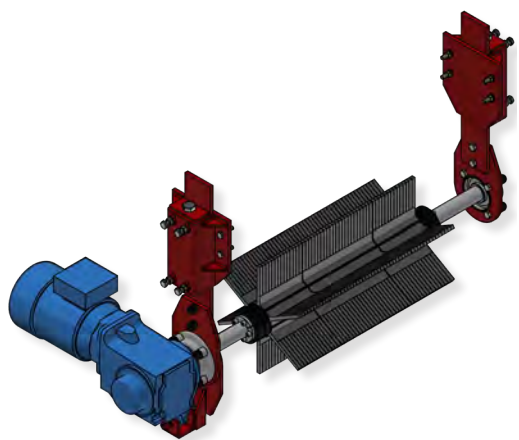

REMACLEAN SGB conveyor belt cleaning brush is ideal for cleaning cleated and chevron belts. Thanks to the glued-on rubber brush cover, effective and gentle cleaning of the conveyor belt is ensured. The spindle clamping device ensures easy assembly and adjustment of the system.

Benefits

- Effective cleaning of cleated and chevron belts
- Highly flexible and extremely gentle on the belt due to rubber bristles
- For belt speeds up to 2.5 m/s
- Easy adjustment thanks to spindle clamping device
- For belt widths from 400 – 1,400 mm

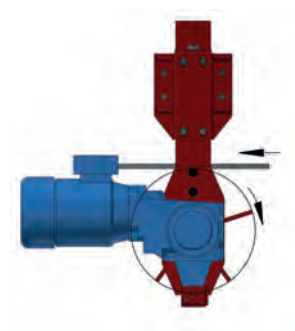

Technical Data

Conveyor Belt Width [mm]	Weight [kg]	A [mm]	B [mm]	C [mm]	D [mm]	Motor Capacity [kw]
400	85	300	700			
500	87	400	800	445	260	1.1
650	91	550	950			
800	96	700	1,150			
900	100	800	1,250	415	235	1.5
1,000	104	950	1,350			
1,200	113	1,100	1,600			
1,400	117	1,300	1,800	475	270	2.2
1,600	126	1,500	2,000			

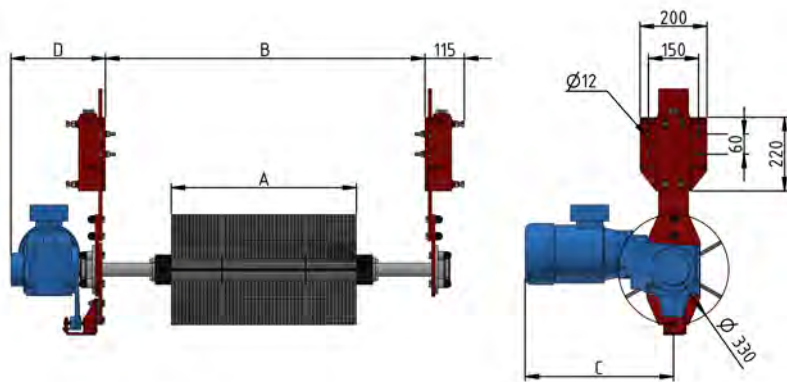

REMACLEAN SGB-PUR

Belt cleaning brushes

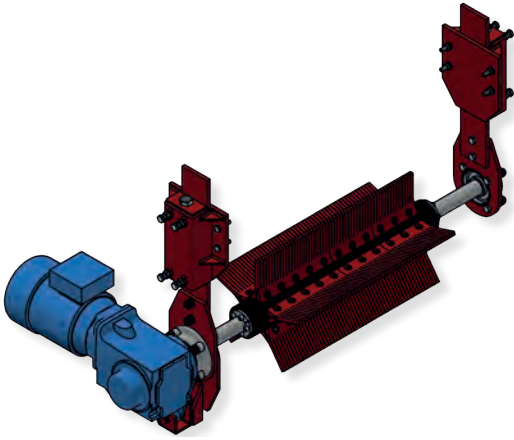

REMACLEAN SGB-PUR conveyor belt cleaning brush is ideal for cleaning cleated and chevron belts. Thanks to the screwed-on, long-life PUR combs, effective and gentle cleaning of the conveyor belt is ensured. The spindle clamping unit ensures easy assembly and adjustment of the system.

Benefits

- Effective cleaning of cleated and chevron belts
- Brush combs made of highly abrasion-resistant polyurethane
- For belt speeds up to 3.5 m/s
- Easy adjustment thanks to spindle clamping device
- For belt widths from 400 – 1,600 mm

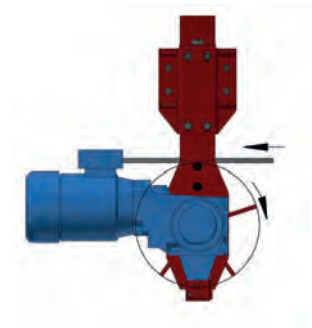

Technical Data

Conveyor Belt Width [mm]	Weight [kg]	A [mm]	B [mm]	C [mm]	D [mm]	Motor Capacity [kw]
400	85	300	700			
500	87	400	800	445	260	1.1
650	91	550	950			
800	96	700	1,150			
900	100	800	1,250	415	235	1.5
1,000	104	950	1,350			
1,200	113	1,100	1,600			
1,400	117	1,300	1,800	475	270	2.2
1,600	126	1,500	2,000			

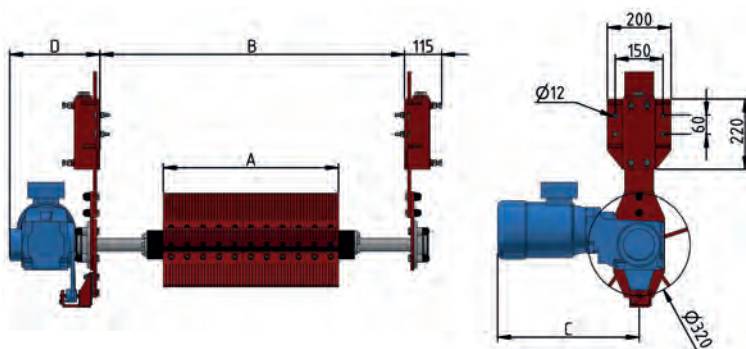

REMACLEAN SGF

Belt cleaning brushes

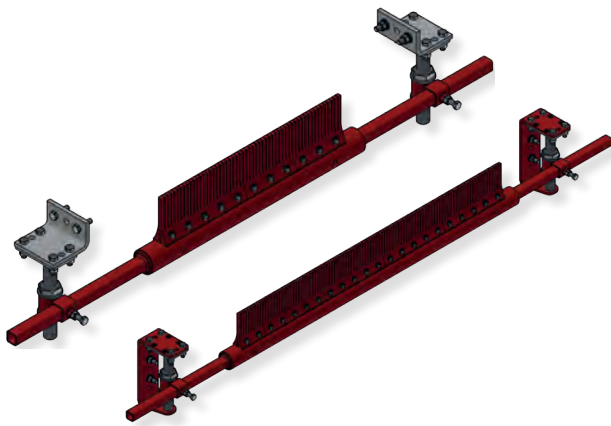

The **REMACLEAN SGF** cleaning bar is specially designed for the cleaning of cleated and chevron belts. The screwed-on, durable PUR combs ensure effective cleaning that is gentle on the conveyor belt. The spindle clamping device ensures easy assembly and adjustment of the system.

Benefits

- Effective cleaning of cleated and chevron belts
- Brush combs made of highly abrasion-resistant polyurethane
- For belt speeds up to 2.5 m/s
- Easy adjustment thanks to spindle clamping device
- For belt widths from 500 – 2,000 mm
- Combs also available in HD (Heavy Duty) version

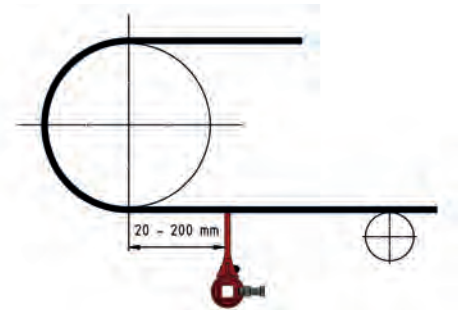

Technical Data

Conveyor Belt Width [mm]	Weight [kg]	A [mm]	B [mm]	C [mm]
500	17	400	566 – 1,266	1,306
650	18	550	716 – 1,416	1,456
800	20	700	866 – 1,563	1,606
1,000	22	950	1,066 – 1,766	1,806
1,200	25	1,100	1,266 – 1,966	2,006
1,400	27	1,300	1,466 – 2,166	2,206
1,600	29	1,500	1,666 – 2,366	2,406
1,800	36	1,700	1,876 – 2,556	2,606
2,000	38	1,900	2,076 – 2,756	2,806

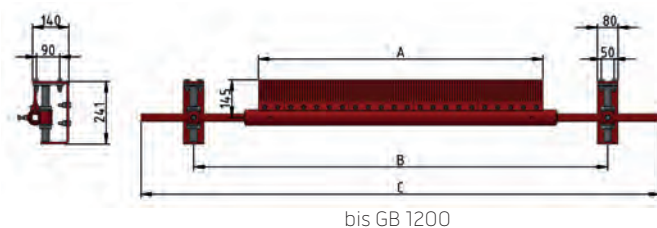
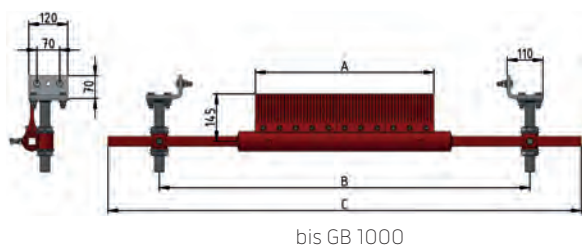

REMACLEAN TMB

Belt cleaning brushes

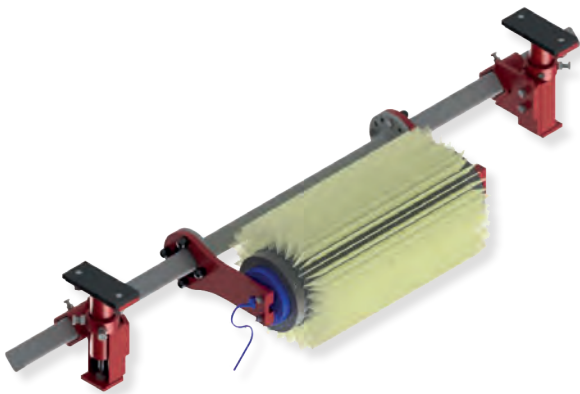

The REMACLEAN TMB drum motor brush with internal drive is ideal for the fine cleaning of smooth conveyor belts. The bristles made of highly abrasion-resistant plastic ensure effective cleaning that is gentle on the conveyor belt. The spindle clamping device is used for easy assembly and adjustment of the system.

Benefits

- Effective fine cleaning of smooth conveyor belts
- Bristles made of highly abrasion-resistant plastic
- For belt speeds up to 6.5 m/s
- Easy adjustment thanks to spindle clamping device
- For belt widths from 400 – 2,000 mm
- Applicable up to 80°C

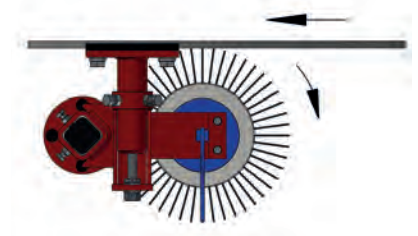

Technical Data

Conveyor Belt Width [mm]	Weight [kg]	A [mm]	B [mm]	C [mm]	D [mm]	E [mm]	F [mm]	G [mm]	Motor Capacity [kW]
400	64	300	490 – 1,200	1,400	300	160	120	M 16	0.75
500	68	400	590 – 1,300	1,500					
650	72	500	690 – 1,450	1,650					
800	77	700	890 – 1,550	1,800					
1,000	106	900	1,090 – 1,850	2,050	325	200	150	M 20	1.5
1,200	118	1,100	1,290 – 2,000	2,200					
1,400	129	1,300	1,490 – 2,200	2,400					
1,600	157	1,500	1,690 – 2,380	2,600					
1,800	167	1,700	1,890 – 2,580	2,800					
2,000	177	1,900	2,090 – 2,780	3,000					

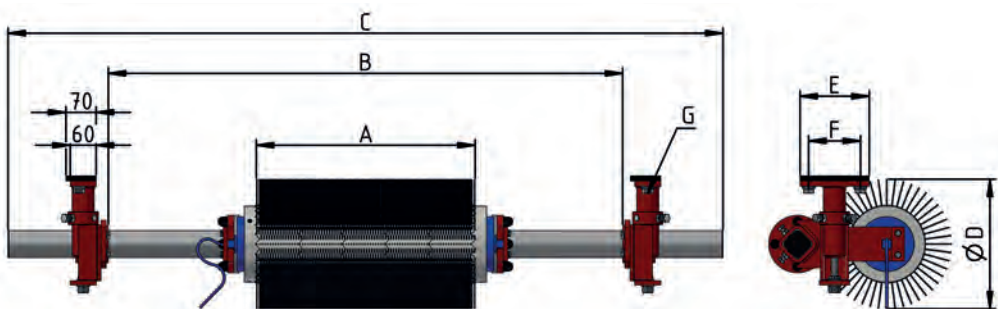

REMACLEAN GRB Belt cleaning brushes

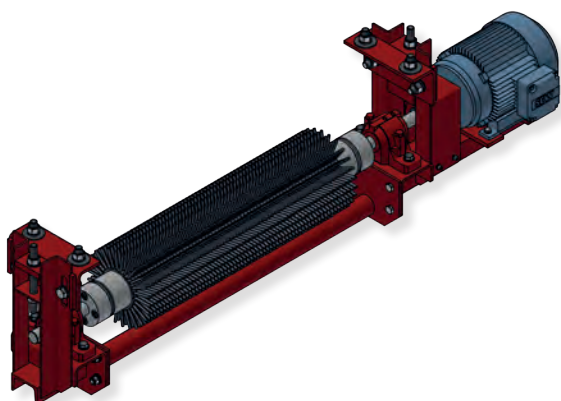

The **REMACLEAN GRB** conveyor belt cleaning brush is ideal for removing fine or pulverized material that adheres only slightly. The nubbed rubber coating ensures effective cleaning that is gentle on the conveyor belt.

Benefits

- Effective cleaning of smooth conveyor belts
- Designed for belt speeds up to 2.5 m/s
- Easy mounting and adjustment thanks to spindle adjustment
- Easy maintenance of the system
- For belt widths from 400 to 2,000 mm

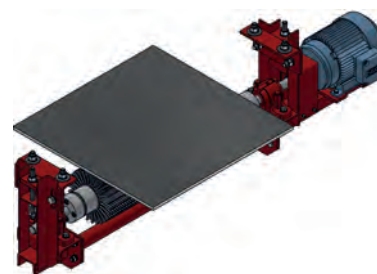

Technical Data

Conveyor Belt Width [mm]	Weight [kg]	A [mm]	B [mm]	C [mm]	D [mm]	Motor Capacity [kW]
400	80	400	779	679	1,197	0.55
500	86	500	986	886	1,437	
650	113	650	1,110	1,010	1,585	
800	116	800	1,377	1,277	1,859	0.75
1,000	119	1,000	1,512	1,412	1,991	
1,200	133	1,200	1,950	1,850	2,436	1.10
1,400	137	1,400	2,150	2,050	2,636	
1,600	140	1,600	2,350	2,250	2,836	
1,800	177	1,800	2,550	2,450	3,127	1.50
2,000	180	2,000	2,750	2,650	3,327	

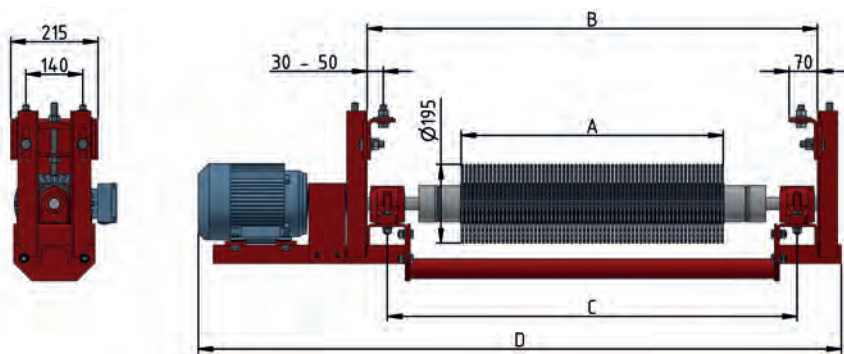

REMACLEAN GBM

Belt cleaning brushes



Electrically driven conveyor belt cleaning brush with plastic bristles and a spindle clamping device. The conveyor belt cleaning brush **REMACLEAN GBM** with an external motor on the inside is ideal for the fine cleaning of smooth conveyor belts. The bristles made of highly abrasion-resistant plastic ensure effective, gentle cleaning of conveyor belts. The spindle clamping device assembly and adjustment of the system.

Benefits

- Effective fine cleaning of smooth conveyor belts
- Bristles made of highly abrasion-resistant plastic
- For belt speeds up to 8.0 m/s
- Easy adjustment thanks to spindle clamping device
- For belt widths from 400 – 2,000 mm
- Applicable up to 80°C

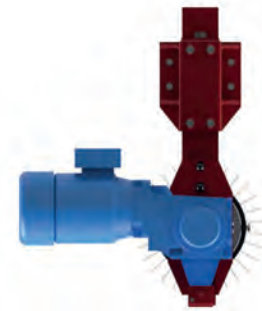

Technical Data

Conveyor Belt Width [mm]	Weight [kg]	A [mm]	B [mm]	C [mm]	D [mm]	E [mm]	F [mm]	Motor Capacity [kw]
400	160	300	12	M10	115	600 – 800	445	1.1
500	165	400				800 – 1,000		
650	170	500				1,000 – 1,200		
800	180	700				1,200 – 1,400		
1,000	210	900	18	M16	140	1,400 – 1,600	415	1.5
1,200	230	947				1,600 – 1,800	444	2.2
1,400	260	1,145				1,800 – 2,000		
1,600	285	1,344				2,000 – 2,200		
1,800	425	1,542				2,200 – 2,400		
2,000	450	1,740				2,400 – 2,600	524	3.0
2,200	475	1,939	2,600 – 2,800					

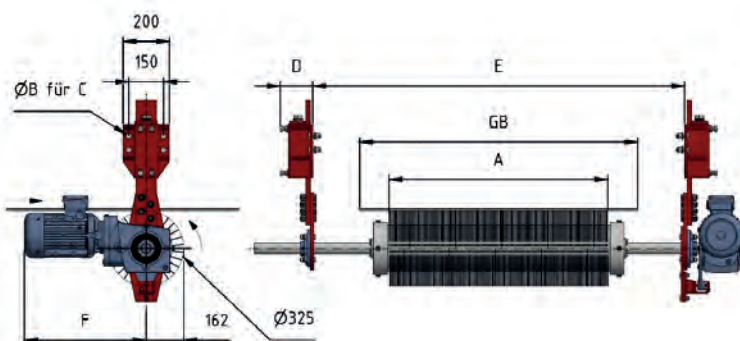

REMACLEAN KWA Cleaning bars



REMACLEAN KWA is a highly abrasion-resistant, universally applicable cross-reversible wiper blade (KWA) made of rubber with a robust steel system carrier and three wiper blades that can be used subsequently. Installation is recommended with the INNOVATION, PRECISION or STANDARD press-on device.

Benefits

- High-performance scraper that protects the belt
- Long service life due to wear-resistant REMA TIP TOP rubber quality
- Excellent cost-performance-ratio
- For belt speeds up to 3.5 m/s

Technical Data

Conveyor Belt Width [mm]	Weight [kg]	A [mm]	B [mm]	C [mm]	D [mm]	E [mm]
500	4.0	480	780	30	90	30x30x4
650	5.0	630	930			
800	6.0	780	1,080			
1,000	12.5	980	1,280	40	12	40x40x5
1,200	14.8	1,180	1,480			
1,400	17.0	1,380	1,680			
1,600	19.3	1,580	1,880			



REMACLEAN PUR Cleaning bars



REMACLEAN PUR is a highly abrasion-resistant, universally applicable scraper bar made of polyurethane with a robust steel system carrier and two scraper bars that can be used subsequently. It is resistant to oil and grease and well suited for use with mechanical connections. Installation is recommended with the INNOVATION, PRECISION or STANDARD press-on device.

Benefits

- High-performance scraper that protects the belt
- Long service life due to wear-resistant REMA TIP TOP rubber quality
- Reverse operation possible in combination with pressure device and reversing stop
- For belt speeds up to 3.5 m/s

Technical Data

Conveyor Belt Width [mm]	Weight [kg]	A [mm]	B [mm]	C [mm]	D [mm]
500	2.8	480	780	20	30x30x4
650	3.5	630	930		
800	4.2	780	1,080		
1,000	9.1	980	1,280	25	40x40x5
1,200	10.7	1,180	1,480		
1,400	12.3	1,380	1,680		
1,600	13.9	1,580	1,880		

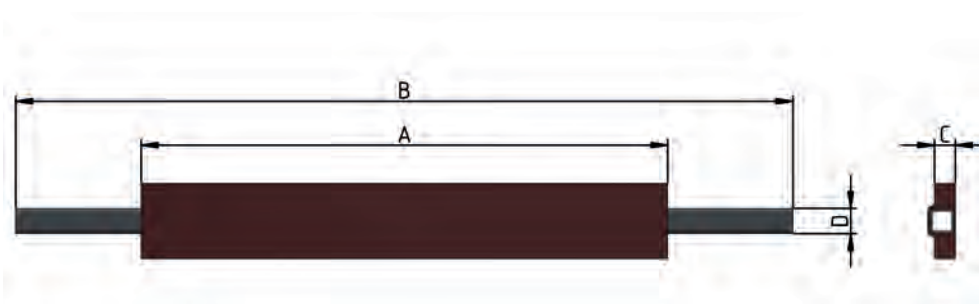

REMACLEAN PUR-LIGHT

Cleaning bars

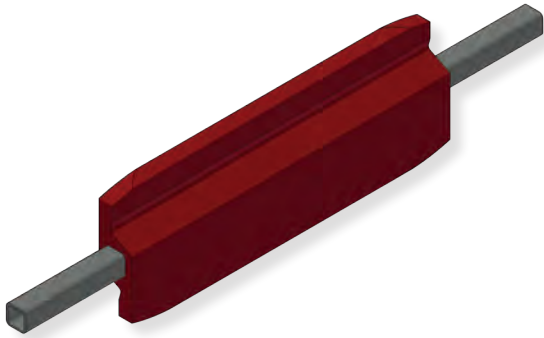

REMACLEAN PUR-LIGHT is a highly abrasion-resistant, universally applicable scraper bar made of polyurethane with a rigid, weight-reduced steel system carrier. The reversible scraper bar features two cleaning sides.

Benefits

- Long service life due to wear-resistant REMA TIP TOP rubber quality
- Excellent cost-performance-ratio
- For belt speeds up to 2.5 m/s
- Available as LEB version for all industries requiring food quality
- Meets requirements of FDA CFR 12§ 177.2600

Technical Data

Conveyor Belt Width [mm]	Weight [kg]	A [mm]	B [mm]
400	3.4	380	680
500	3.9	480	780
650	4.9	630	930
800	6.2	780	1,080
1,000	7.5	980	1,280
1,200	8.9	1,180	1,480
1,400	10.3	1,380	1,680

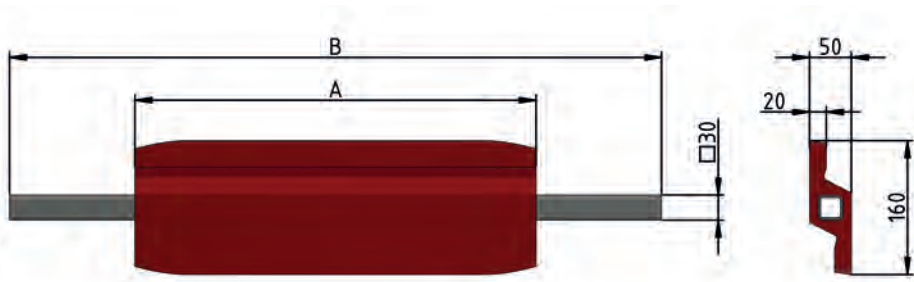

REMACLEAN M

Cleaning bars



REMACLEAN M is a highly abrasion-resistant rubber scraper bar for universal use with tungsten carbide inserts flexibly embedded in rubber and a rigid steel construction. Due to the rounded outer carbide inserts belt friendly cleaning is ensured.

Benefits

- Long service life due to wear-resistant REMA TIP TOP rubber quality and embedded carbide plates
- Excellent cost-performance-ratio
- For belt speeds up to 3.5 m/s
- Not suitable for mechanic connections

Technical Data

Conveyor Belt Width [mm]	Weight [kg]	A [mm]	B [mm]	C [mm]	D [mm]
400	3.0	380	680	60	30x30x4
500	3.5	480	780		
650	4.0	630	930		
800	5.0	780	1,080	80	40x40x5
1,000	9.0	980	1,280		
1,200	11.0	1,180	1,480		
1,400	12.0	1,380	1,680		
1,600	14.0	1,580	1,880		

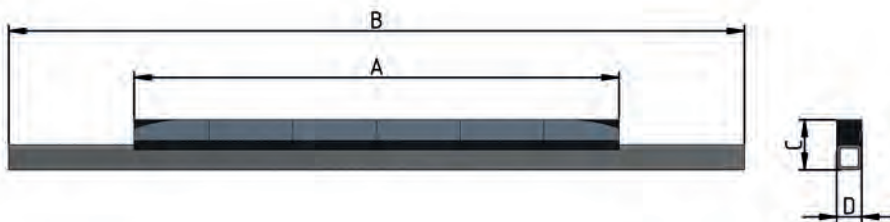

REMACLEAN C

Cleaning bars



REMACLEAN C is a highly abrasion-resistant rubber scraper bar for universal use with ceramic material flexibly embedded in rubber and a rigid steel construction. Belt friendly cleaning is guaranteed due to rounded outer ceramic elements.

Benefits

- Long service life due to wear-resistant REMA TIP TOP rubber quality and embedded ceramic stones
- Excellent cost-performance-ratio
- For belt speeds up to 3.5 m/s
- Not suitable for mechanic connections

Technical Data

Conveyor Belt Width [mm]	Weight [kg]	A [mm]	B [mm]	C [mm]	D [mm]
400	3.0	380	680	60	30x30x4
500	3.5	480	780		
650	4.0	630	930		
800	5.0	780	1,080		
1,000	8.0	980	1,280	80	40x40x5
1,200	10.0	1,180	1,480		
1,400	11.0	1,380	1,680		
1,600	12.0	1,580	1,880		

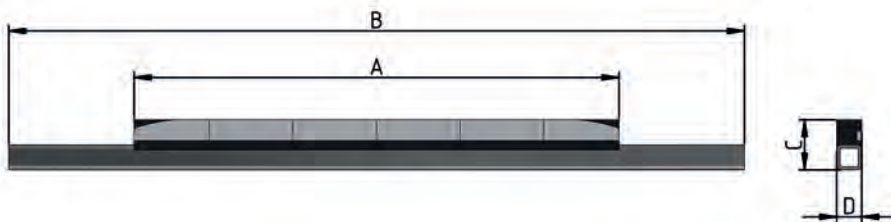

REMACLEAN HML

Cleaning bars



Highly abrasion-resistant, universally applicable cleaning bar made of carbide with non-stick coating and a robust steel system carrier. A special version made of stainless steel, galvanized or chrome-plated is possible. Recommended installation with INNOVATION press-on device.

Benefits

- Powerful and belt-friendly
- Long service life thanks to the use of highly abrasion-resistant carbide
- Universal use with many conveyed goods
- Belt speeds up to 4.0 m/s
- Not suitable for use with mechanical joints
- HML HR version for temperatures up to 300°C
- HML type 15 developed for particularly abrasive conveyed material

Technical Data

Conveyor Belt Width [mm]	Weight [kg]	A [mm]	B [mm]	C [mm]
400	4.7	360	720	30x30x4
500	6.1	480	840	
650	7.3	600	960	
800	8.6	720	1,080	40x40x5
1,000	12.2	960	1,360	
1,200	19.4	1,080	1,480	
1,400	23.2	1,320	1,720	

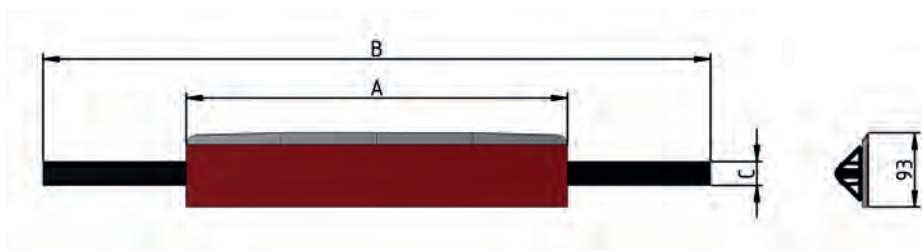

OVERVIEW: U-Series

REMACLEAN – Belt cleaning systems for belt return side applications



Description	HM-U1	HM-U2	HM-U3	HM-U7	HM-U8
Belt width [mm]	400–2,400	500–1,400	400–1,200	400–1,400	800–2,000
Type of cleaning (H/V)	V, H	V, H	V, H	F	F
max. speed [m/s]	6.5	6.5	4.0	4.0	6.5
for reversing operation	yes*	yes*	no	no	no
Type of cleaning bar (S/D)	S	D	D	S	S
material of cleaning bar	HM	HM	HM	HM	HM
max. temperature [°C]	120**	60	80	60	60
ATEX suitable	yes**	no	yes	yes**	yes**
Use for mechan. Fasteners	nein	no	no	yes**	yes**
for food applications	yes**	no	yes**	no	no
Oil- and fat-containing goods	●	●	●	●	●
Sand / gravel (dry)	●	●	●	●	●
Sand / Kies (wet)	●	●	●	●	●
Coal (crude)	●	●	●	●	●
lignite / overburden	●	●	●	●	●
Ores	●	●	●	●	●
Sinter	●	●	●	●	●
Clay	●	●	●	●	●
Cement	●	●	●	●	●
Gypsum / lime (dry)	●	●	●	●	●
Gypsum / lime (wet)	●	●	●	●	●
Waste	● ●	●	●	●	●

V = Pre-cleaner (Primary), H = Main cleaner (Secondary), G = Rough cleaner, F = Fine cleaner, S = Segments, D = Continuous bar, HM = Carbide, PUR = Polyurethane
* = with reversing stop, ** = as a special version ● = recommended, ● = conditionally suitable, ● = not recommended

The exemplary recommendations on the use of the products are based on application-technical experience, but are not a guarantee for their use. Suitability in specific areas of application and do not exempt the user from self-examination. In individual cases, we recommend an application-technical consultation to obtain – experienced specialists from REMA TIP TOP are available for this purpose.

OVERVIEW: F-Series

REMACLEAN – Belt cleaning systems for use on the pulley

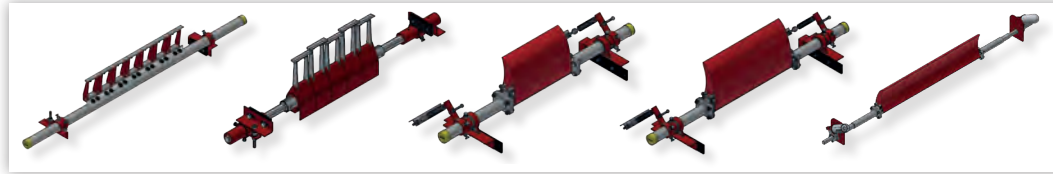

Description	HM-F2	HM-F2 PUR	PUR-F3	PUR-F4	PUR-F4 HD
Belt width [mm]	400–2,000	500–2,000	400–2,200	800–2,400	800–2,000
drum diameter [mm]	160–1,000	300–1,000	160–800	500–1,000	500–1,000
Type of cleaning (H/V)	V, H	V, H	V	V	V
max. speed [m/s]	4.5	4.5	4.0	4.0	5.0
for reversing operation	yes	yes	yes	yes	yes
Type of cleaning bar (S/D)	S	S	S / D (Type Mono)	S / D (Type Mono)	S / D (Type Mono)
material of cleaning bar	HM	HM	PUR	PUR	PUR
max. temperature [°C]	120**	60	60	60	60
ATEX suitable	no	ja**	ja**	ja**	ja**
Use for mechan. Fasteners	no	no	yes	yes	yes
for food applications	ja**	no	no	no	no
Oil- and fat-containing goods	●	●	●	●	●
Sand / gravel (dry)	●	●	●	●	●
Sand / Kies (wet)	●	●	●	●	●
Coal (crude)	●	●	●	●	●
lignite / overburden	●	●	●	●	●
Ores	●	●	●	●	●
Sinter	●	●	●	●	●
Clay	●	●	●	●	●
Cement	●	●	●	●	●
Gypsum / lime (dry)	●	●	●	●	●
Gypsum / lime (wet)	●	●	●	●	●
Waste	●	●	● Type Mono	● Type Mono	● Type Mono

V = Pre-cleaner (Primary), H = Main cleaner (Secondary), G = Rough cleaner, F = Fine cleaner, S = Segments, D = Continuous bar, HM = Carbide, PUR = Polyurethane
 * = with reversing stop, ** = as a special version ● = recommended, ● = conditionally suitable, ● = not recommended

The exemplary recommendations on the use of the products are based on application-technical experience, but are not a guarantee for their use. Suitability in specific areas of application and do not exempt the user from self-examination. In individual cases, we recommend an application-technical consultation to obtain – experienced specialists from REMA TIP TOP are available for this purpose.

OVERVIEW: I-Series

REMACLEAN – Belt cleaning systems for use on the inner belt



Description	RB-IGD	RB-IGP-S
Belt width [mm]	500–1,600	500–1,600
Type of cleaning (H/V)	G	G
max. speed [m/s]	3.5	4.0
for reversing operation	yes	no
Type of cleaning bar (S/D)	D	#
material of cleaning bar	Rubber / PE	Rubber / PE
max. temperature [°C]	70	70
ATEX suitable	yes**	yes**
Use for mechan. Fasteners	yes	yes**
for food applications	yes**	yes**
Oil- and fat-containing goods	●	●
Sand / gravel (dry)	●	●
Sand / Kies (wet)	●	●
Coal (crude)	●	●
lignite / overburden	●	●
Ores	●	●
Sinter	●	●
Clay	●	●
Cement	●	●
Gypsum / lime (dry)	●	●
Gypsum / lime (wet)	●	●
Waste	●	●

V = Pre-cleaner (Primary), H = Main cleaner (Secondary), G = Rough cleaner, F = Fine cleaner, S = Segments, D = Continuous bar, HM = Carbide, PUR = Polyurethane
 * = with reversing stop, ** = as a special version ● = recommended, ● = conditionally suitable, ● = not recommended

The exemplary recommendations on the use of the products are based on application-technical experience, but are not a guarantee for their use. Suitability in specific areas of application and do not exempt the user from self-examination. In individual cases, we recommend an application-technical consultation to obtain – experienced specialists from REMA TIP TOP are available for this purpose.

OVERVIEW: Belt cleaning brushes

REMACLEAN – Belt cleaning systems for use on the track

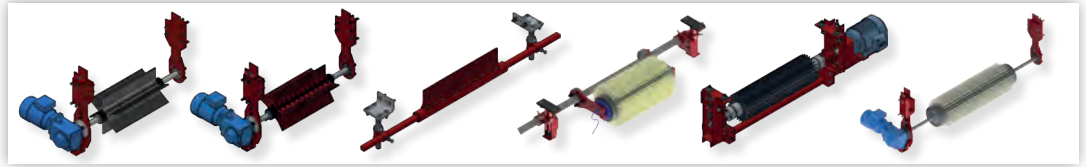

Description	SGB	SGB-PUR	SGF	TMB	GRB	GBM
Belt width [mm]	400–1,400	400–1,600	500–2,000	400–2,000	400–2,000	400–2,000
Type of cleaning (H/V)	H	H	V, H	F	F	F
max. speed [m/s]	2.5	3.5	2.5	6.5	2.5	8.0
for reversing operation	yes	yes	yes	yes	yes	yes
material of cleaning bar	Rubber	PUR	PUR	Plastic	Rubber	Plastic
max. temperature [°C]	70	70	70	80	70	80
ATEX suitable	no	yes**	yes**	no	yes**	no
Use for mechan. Fasteners	yes	yes	yes	no	yes	no
for food applications	no	no	no	yes**	yes**	yes**
Oil- and fat-containing goods	●	●	●	●	●	●
Sand / gravel (dry)	●	●	●	●	●	●
Sand / Kies (wet)	●	●	●	●	●	●
Coal (crude)	●	●	●	●	●	●
lignite / overburden	●	●	●	●	●	●
Ores	●	●	●	●	●	●
Sinter	●	●	●	●	●	●
Clay	●	●	●	●	●	●
Cement	●	●	●	●	●	●
Gypsum / lime (dry)	●	●	●	●	●	●
Gypsum / lime (wet)	●	●	●	●	●	●
Waste	● ●	● ●	● ●	●	● ●	●

V = Pre-cleaner (Primary), H = Main cleaner (Secondary), G = Rough cleaner, F = Fine cleaner, S = Segments, D = Continuous bar, HM = Carbide, PUR = Polyurethane
 * = with reversing stop, ** = as a special version ● = recommended, ● = conditionally suitable, ● = not recommended

The exemplary recommendations on the use of the products are based on application-technical experience, but are not a guarantee for their use. Suitability in specific areas of application and do not exempt the user from self-examination. In individual cases, we recommend an application-technical consultation to obtain – experienced specialists from REMA TIP TOP are available for this purpose.

OVERVIEW: Cleaning bars

REMACLEAN – Belt cleaning systems for use on the track

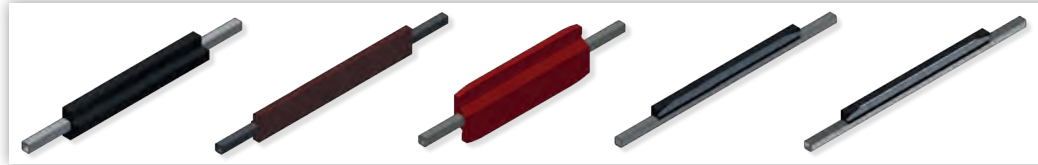

Description	KWA	PUR	PUR-LIGHT	M	C
Belt width [mm]	500–1,600	500–1,600	500–1,600	400–1,600	400–1,600
Type of cleaning (H/V)	V, H	V, H	V, H	V, H	V, H
max. speed [m/s]	3.5	3.5	2.5	3.5	3.5
for reversing operation	no	yes	yes	no	no
Type of cleaning bar (S/D)	D	D	D	D	D
material of cleaning bar	Rubber	PUR	PUR	Rubber/Metal	Rubber/Ceramik
max. temperature [°C]	70	70	70	70	70
ATEX suitable	yes**	yes**	yes**	yes**	yes**
Use for mechan. Fasteners	yes	yes	yes	no	no
for food applications	no	no	no	no	no
Oil- and fat-containing goods	●	●	●	●	●
Sand / gravel (dry)	●	●	●	●	●
Sand / Kies (wet)	●	●	●	●	●
Coal (crude)	●	●	●	●	●
lignite / overburden	●	●	●	●	●
Ores	●	●	●	●	●
Sinter	●	●	●	●	●
Clay	●	●	●	●	●
Cement	●	●	●	●	●
Gypsum / lime (dry)	●	●	●	●	●
Gypsum / lime (wet)	●	●	●	●	●
Waste	●	●	●	●	●

V = Pre-cleaner (Primary), H = Main cleaner (Secondary), G = Rough cleaner, F = Fine cleaner, S = Segments, D = Continuous bar, HM = Carbide, PUR = Polyurethane
* = with reversing stop, ** = as a special version ● = recommended, ● = conditionally suitable, ● = not recommended

The exemplary recommendations on the use of the products are based on application-technical experience, but are not a guarantee for their use. Suitability in specific areas of application and do not exempt the user from self-examination. In individual cases, we recommend an application-technical consultation to obtain – experienced specialists from REMA TIP TOP are available for this purpose.

OVERVIEW: Cleaning bars



	HML Typ 16	HML Typ 15	HML HR	HML CHROM
	400–1,400	400–1,400	400–1,400	400–1,400
	V, H	V, H	V, H	V, H
	4.0	4.0	4.0	4.0
	no	no	no	no
	D	D	D	D
	HM	HM	HM	HM
	60	60	300	300
	no	no	yes	yes
	no	no	no	no
	no	no	no	yes
	●	●	●	●
	●	●	●	●
	● ●	●	● ●	● ●
	●	●	●	●
	●	●	●	●
	●	●	●	●
	●	●	●	●
	●	●	●	●
	●	●	●	●
	●	●	●	●
	●	●	●	●
	●	●	●	●

V = Pre-cleaner (Primary), H = Main cleaner (Secondary), G = Rough cleaner, F = Fine cleaner, S = Segments, D = Continuous bar, HM = Carbide, PUR = Polyurethane
 * = with reversing stop, ** = as a special version ● = recommended, ● = conditionally suitable, ● = not recommended

The exemplary recommendations on the use of the products are based on application-technical experience, but are not a guarantee for their use. Suitability in specific areas of application and do not exempt the user from self-examination. In individual cases, we recommend an application-technical consultation to obtain – experienced specialists from REMA TIP TOP are available for this purpose.

QUESTIONNAIRE:
REMACLEAN belt cleaning systems

Customer:	Contact person:
Phone:	Fax:
Address:	Country (representation):
	E-Mail:

Information about conveyor equipment

Belt designation:	Type / brand:	Belt thickness (mm):		
Belt width (mm):	Axial distances (m):	Belt speed (m/s):		
Belt surface:	<input type="checkbox"/> New	<input type="checkbox"/> Used / smooth	<input type="checkbox"/> Damaged	<input type="checkbox"/> Heavily damaged
Belt splice:	<input type="checkbox"/> Cold	<input type="checkbox"/> Hot	<input type="checkbox"/> Mechanical/Type	
Pulley diameter (mm):		Pulley shape:	<input type="checkbox"/> Cylindric	<input type="checkbox"/> Curved
Pulley Lagging <input type="checkbox"/> Yes <input type="checkbox"/> No:	Attachment	<input type="checkbox"/> Cold	<input type="checkbox"/> Hot	<input type="checkbox"/> Mechanical
Pulley lagging designation:		Reverse mode:	<input type="checkbox"/> Yes	<input type="checkbox"/> No
Operating time:	hours per day:			hours per week
Temperature at the position of the belt cleaning system:		°C		
Remarks:				

Material conveyed

Moisture content:		%:	Tends to dry or harden	<input type="checkbox"/> Yes	<input type="checkbox"/> No
Quartz content:	<input type="checkbox"/> Yes,	%:	<input type="checkbox"/> No		
Sticky admixture content:					

Installed cleaning system

Manufacturer:	Type:
Assessment of the cleaning performance:	
Remarks:	

Information prepared by:

Place and date	Name	Signature
----------------	------	-----------

Recommendation for a new belt cleaning system

Type:	Ref. No.:
Remarks:	

Recommendation prepared by:

Place and date	Name	Signature
----------------	------	-----------

QUESTIONNAIRE:
REMACLEAN belt cleaning systems

Customer:	Contact person:
Phone:	Fax:
Address:	Country (representation):
	E-Mail:

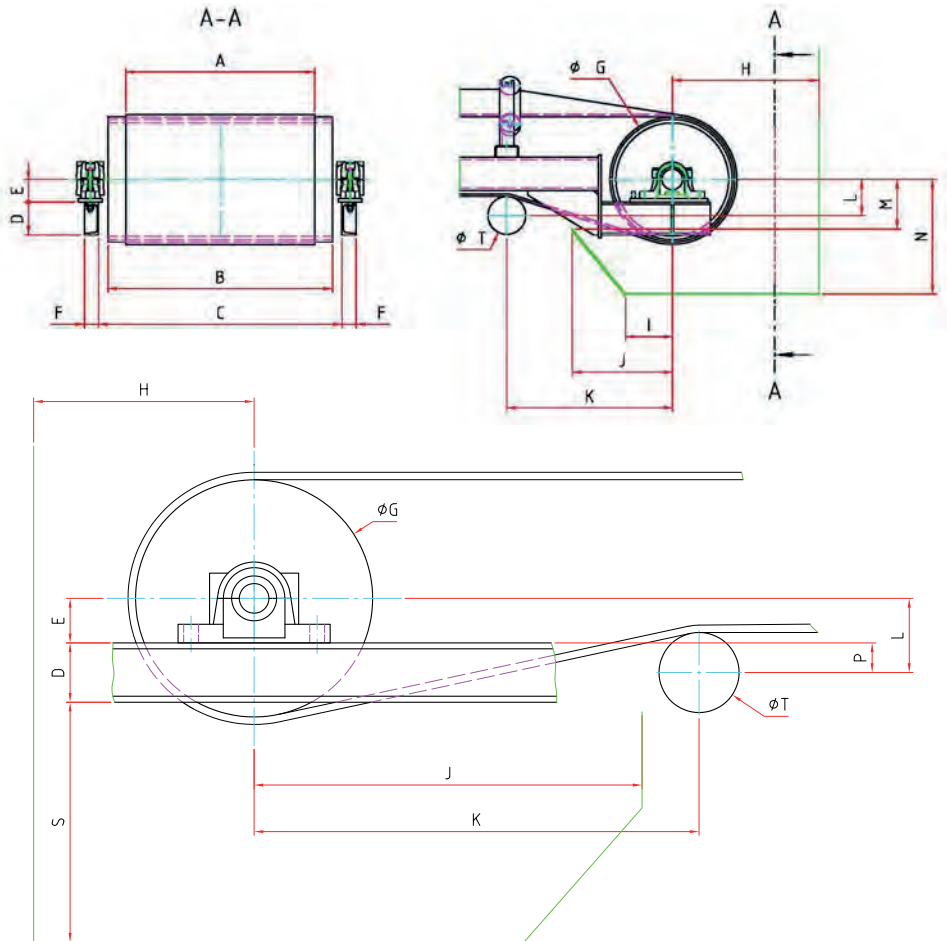

A	I	
B	J	
C	K	
D	L	
E	M	
F	N	
G	T	
H	P	S=

Remarks:



Your local contact



// ONE BRAND // ONE SOURCE // ONE SYSTEM

REMA TIP TOP AG
Gruber Strasse 65 · 85586 Poing / Germany
Phone: +49 8121 707-100
Fax: +49 8121 707-10 222
info@tiptop.de
www.rema-tiptop.com

