



// ONE BRAND // ONE SOURCE // ONE SYSTEM



REMA TIP TOP SURFACE PROTECTION

HIGH-QUALITY CORROSION PROTECTION SYSTEMS FROM A SINGLE SOURCE

ONE BRAND – ONE SOURCE – ONE SYSTEM

TIP TOP Oberflächenschutz Elbe GmbH, headquartered in Lutherstadt Wittenberg, Germany, and with production facilities in Wittenberg and Warstein, is a 100% subsidiary of the REMA TIP TOP AG, specializing in all aspects of corrosion protection. The REMA TIP TOP product range is designed to protect against corrosion and wear, and continues to set new standards in the industry.

In order to further expand the product and service portfolio for the international customers of the REMA TIP TOP SURFACE PROTECTION segment, SKO Säureschutz GmbH joined the network in 2014. The company completes the segment's portfolio with its expertise in industrial acid construction.

The materials used in the REMA TIP TOP portfolio of products for corrosion protection are own developments that exhibit a high degree of resistance against exposure to chemical, thermal and mechanical stresses. Our experienced application specialists determine – on the basis of the project and if necessary on-site - the optimal or most economic corrosion and wear protection system for every type of stress.

Experienced chemical engineers and technicians continually develop new materials for the Surface Protection segment and improve existing materials or modify these to meet new legislation requirements as necessary.

Many of the materials have general approval from the German Institute for Construction Technology (DIBt) and are certified according to the latest requirements for the use in the food and drinking water sector or have the approval for the use in nuclear installations.

This ensures that the selected material carries out its task optimally and meets legislative requirements, thus ensuring that your plant continues to operate economically and effectively.



REMA TIP TOP AG in Poing



TIP TOP Oberflächenschutz Elbe GmbH in Wittenberg

CONTENTS

1. RUBBER LINING MATERIALS	4
1.1 Workshop rubber lining	5
▪ Soft rubber linings	6
▪ Hard rubber linings	6
1.2 On-site rubber linings	7
▪ Self-vulcanizing rubber linings	7
▪ Vulcanized rubber linings	7
▪ Rubber linings vulcanized with steam or hot water	7
2. COATINGS FOR CONTAINER VESSELS, FLUE GAS SCRUBBERS, FLUE CHANNELS, CHIMNEYS	9
3. COATINGS FOR DRUMS AND ROLLERS	12
4. COATINGS FOR INDUSTRIAL FLOORING, COLLECTION PITS AND WAREHOUSES	13
5. FLUOROPOLYMER LININGS	15
6. ACID-PROOF BRICK LININGS	16
7. ACID-PROOF AND HEAVY-DUTY CORROSION PROTECTION WITH COMBINED LININGS	17
8. OUR STANDARD OF SERVICE – A PERFECT PROCESS	18

1. RUBBER LINING MATERIALS

Corrosion causes billions of dollars in damage to industries worldwide each year. REMA TIP TOP corrosion protection systems prevent such damage and maintain the value of your plant while contributing to environmental protection. Wherever chemicals and abrasive materials cause damage to vessels, flue gas scrubbers, thickeners, pipes, valves etc., we offer corrosion and wear protection solutions from a single source.

REMA TIP TOP is also known for its excellent service. With its own offices, subsidiaries and partner companies in more than 170 countries, REMA TIP TOP is always close to its customers. The fast response times of our service teams mean that our customers do not incur high costs due to long downtimes.

In the REMA TIP TOP Surface Protection segment, soft rubber linings are used under the brand name "CHEMOLINE" and hard rubber linings under the brand name "CHEMONIT". Our rubber sheets are produced on an ultra-modern roller head system with an integrated vacuum extruder. This is the only way to produce pore-free and absolutely homogeneous rubber sheets that guarantee long service life.

CHEMOLINE soft rubber lining – vulcanized:

In these soft rubber linings, such as CHEMOLINE 4 CN, the rubber sheets are vulcanized and contain an easy-to-bond CN base layer. These rubber sheets can be bonded to both steel and concrete substrates. These lining materials are applied with special REMA TIP TOP adhesives and do not require further vulcanization. The applied rubber lining can be put directly into service without any further loss of time due to a vulcanization process.

Typical build-up, using CHEMOLINE 4 CN as example

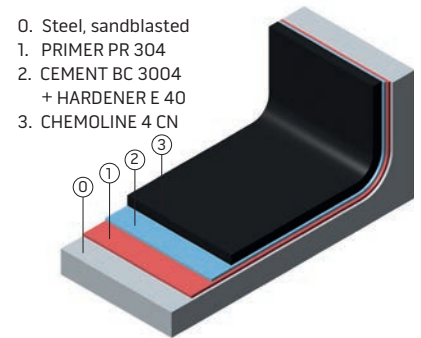

CHEMOLINE soft rubber lining – un-vulcanized or self-vulcanizing:

Un-vulcanized CHEMOLINE soft rubber lining products are normally vulcanized in an autoclave. However they can also be vulcanized on the construction site with steam or hot water. Specially developed rubber lining materials and adhesives can be used up to an operating temperature of 120 °C after vulcanization.

Self-vulcanizing soft rubber lining compounds also vulcanize at ambient temperatures over a longer period of time (months). For certain media, partial vulcanization is often sufficient and full vulcanization then occurs under operating conditions.

Typical build-up, using CHEMOLINE 4 B as example

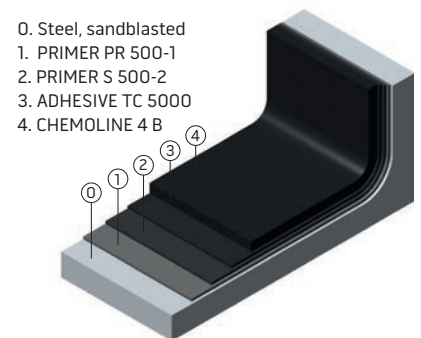

CHEMONIT hard rubber lining

CHEMONIT hard rubber lining materials are applied un-vulcanized and must be subsequently vulcanized. Vulcanization is normally carried out in an autoclave under temperature and pressure. Special hard rubber lining compounds can also be vulcanized on the construction site with steam or hot water.

Typical build-up, using CHEMONIT 181 as example

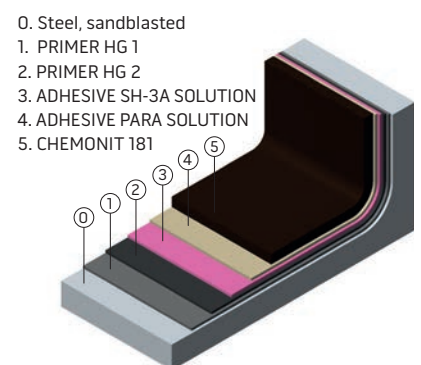

1. RUBBER LINING MATERIALS

1.1. WORKSHOP RUBBER LINING

For components that fit into an autoclave and can be transported, such as pipes, flue gas scrubbers, quench towers, venturi scrubbers, filter and storage tanks, reaction and pickling tanks, centrifuges, road and railway tanks, valves as well as rollers and drums, REMA TIP TOP workshop rubber linings offer optimal protection.

REMA TIP TOP workshop rubber lining is eminently suitable not only for acid, lye and salt solutions whose effects are increased by high temperatures or temperature change, it is also excellently suited to mechanical stresses.

REMA TIP TOP has developed a comprehensive range of materials for the workshop rubber lining sector. This forms the basis for an individual choice of rubber qualities to match the various applications or exposures concerned.



Workshop rubber lining in Wittenberg

Workshop rubber lining consists of rubber sheets that are applied un-vulcanized on the prepared component substrate and then vulcanized in an autoclave at high temperature (110 to 145 °C) and pressure (3 to 6 bar).

Steam or hot air is used as the thermal transfer medium in autoclaves. To ensure the long-term success of the protective lining, a program that is specifically developed for the material concerned controls the heating-up, constant temperature period and the subsequent cooling-off of the autoclave.

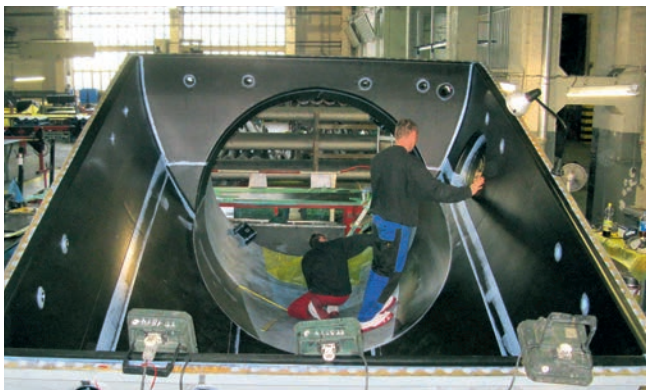

Rubber-lined water chamber

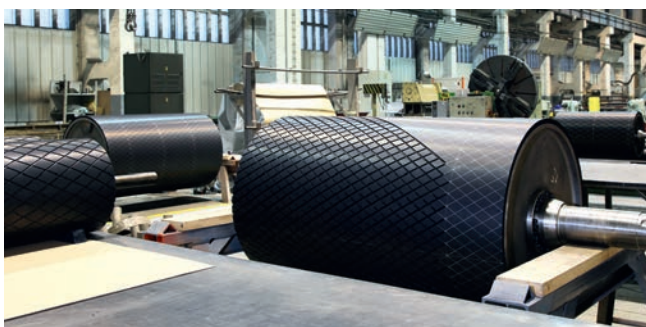

Rubber lining of drive drums



Railway tank center in Wittenberg



Workshop rubber lining in Warstein

1. RUBBER LINING MATERIALS

There are basically two groups of workshop rubber lining materials.

Soft rubber linings

are characterized by being particularly flexible – even for mechanically less stable components.

The material is described as being soft rubber only after it has completely vulcanized.

Hard rubber linings

can only be used for mechanically stable components. It is largely based on natural rubber, but mixtures of natural rubber (NR) and polyisoprene (IR) or styrol-butadiene (SBR) are possible.

The following rubbers are used for soft rubber linings:

- Natural rubber (NR)
- Chloroprene rubber (CR)
- Butyl rubber (IIR)
- Chlorobutyl rubber (CIIR)
- Bromobutyl rubber (BIIR)
- Chlorosulfonated polyethylene (CSM)
- Nitrile rubber (NBR)



Quench column in the Wittenberg workshop rubber lining plant

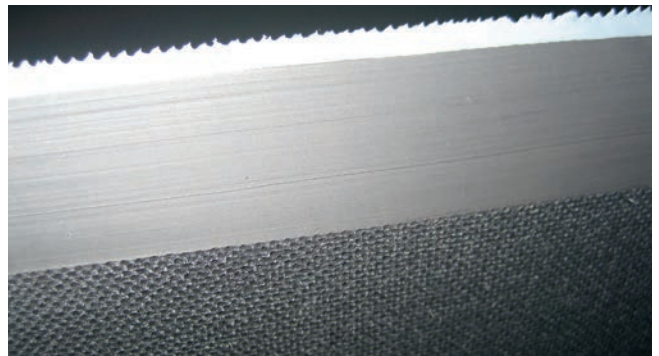

Section through a homogeneous pore-free REMA TIP TOP rubber lining



Railroad tank wagons hall in Wittenberg



Rubber-lined flow-meter pipe

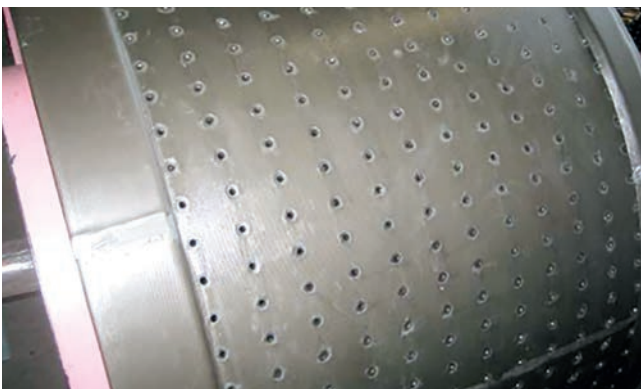

Rubber-lined centrifuge



Rubber-lined container

1. RUBBER LINING MATERIALS



Rubber-lined thickener

1.2. ON-SITE RUBBER LININGS

REMA TIP TOP has developed rubber linings for all industrial sectors that can be used on site no matter what the size of the component is. These on-site rubber linings offer optimal perfection for storage containers, pipes, reaction vessels, flue gas scrubbers and others, but also for concrete components such as waste water sewers and deionizing and neutralization basins. REMA TIP TOP on-site rubber lining is eminently suitable not only for acid, lye and salt solutions whose effects are increased by high temperatures or temperature change; it is also excellently suited to mechanical stresses.

Different materials are used depending on the requirements and the circumstances on site.

Self-vulcanizing rubber linings

must be stored in a cool place between the time of manufacture and application. These are soft rubber linings that are applied un-vulcanized onto the substrate and then self-vulcanize over a longer period of time (several months) by temperatures of more than 25 °C. This process can be accelerated by vulcanizing with steam or hot water.

Vulcanized rubber linings

are single or doublelayer soft rubber sheets that are wrapped onto rolls before application and vulcanized in an autoclave, allowing them to be stored without cooling. After application, the rubber lining can be put into operation within two days (time required for the chemical reaction of the adhesive).

Rubber linings vulcanized with steam or hot water

For the protection of vessels of up to 1000 m³ capacity, the rubber sheets can be vulcanized with steam or hot water. To do so the vessel is filled with water after applying the rubber sheets that is then heated to 95 to 98 °C in several hours using steam. If the components are designed to be used under pressure, vulcanization can also be carried out using steam only. Vulcanized elements using hot water or steam are comparable to rubber linings vulcanized in an autoclave with regards to adhesion to substrate, seam sealing and chemical resistance. The procedure can be used for both soft and hard rubber linings.

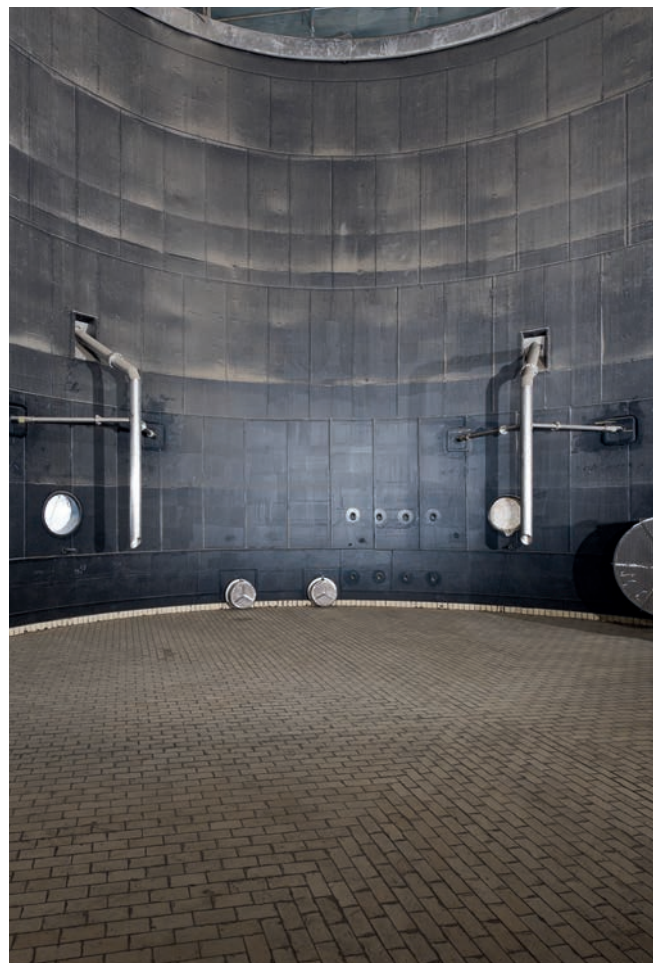

Rubber-lined flue gas scrubber

1. RUBBER LINING MATERIALS

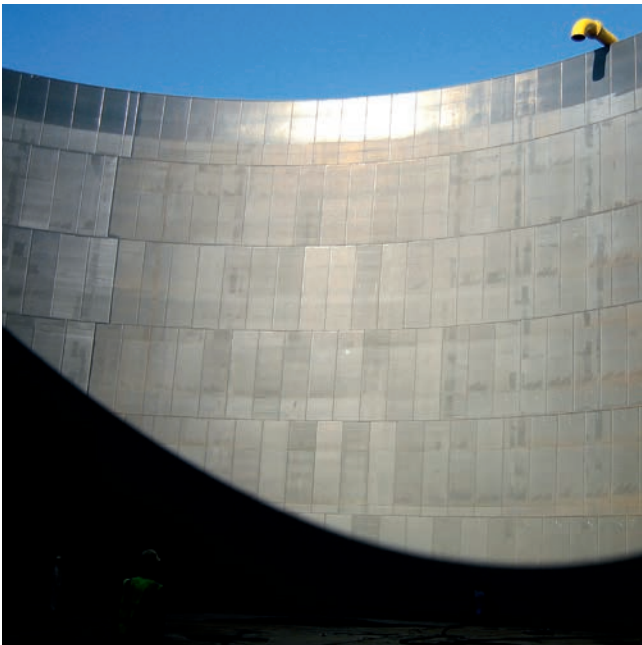

Rubber lining of phosphoric acid storage tank

REMA TIP TOP uses the following types of rubber for on-site applications:

- Bromobutyl rubber (BIIR)
- Chlorobutyl rubber (CIIR)
- Chloroprene rubber (CR)
- Natural rubber (NR)
- Hypalon (CSM)
- Isoprene rubber/Styrol-butadiene rubber (IR/SBR)
- Bromobutyl/Polyvinylchloride (BIIR/PVC)
- Chlorobutyl rubber/Chloroprene rubber (CIIR/CR)



Delivery of rubber-lined thickener parts



Rubber-lined sedimentation tank

2. COATINGS FOR CONTAINER VESSELS, FLUE GAS SCRUBBERS, FLUE CHANNELS, CHIMNEYS

For reliable long-term corrosion protection in process plants, synthetic resins from REMA TIP TOP are being used increasingly.

REMA TIP TOP carries a large variety of coating materials for use in a wide range of industrial application areas.

Our range of coating materials offers exceptional chemical and thermal resistance. Our spray, trowelling and laminate coatings for corrosion protection are manufactured on the basis of epoxy, vinyl ester, furane and phenol resins as well as polyester resins and contain various fillers.

REMA TIP TOP chooses a suitable material based on the operational load parameters, the substrate and the point of application. Our coating materials are distributed under the brand names COROFLAKE, TIP TOP LINING, TOPLINE, and Asplit.



Lined flue gas scrubber



Coated power station chimney



Coated clean gas duct

2. COATINGS FOR CONTAINER VESSELS, FLUE GAS SCRUBBERS, FLUE CHANNELS, CHIMNEYS



COROFLAKE coating in an absorber



Coated chimney



COROFLAKE coating in a wet ESP



Installing a laminate coating

2. COATINGS FOR CONTAINER VESSELS, FLUE GAS SCRUBBERS, FLUE CHANNELS, CHIMNEYS

COROFLAKE troweled coatings

The COROFLAKE systems applied with trowel are coatings for the protection of metallic parts from aggressive media under permanent wet immersion. They are based on polyester and vinyl ester resins and are strengthened with micro-thin C-glass flakes. The resins used offer outstanding protection against chemicals, while the glass flakes, which are aligned parallel to the substrate, offer excellent permeation resistance. A nominal thickness of 2.0 mm is achieved with only two layers. **These COROFLAKE trowelled coatings can be used up to a wet temperature of 90 °C.**

Typical build-up, using COROFLAKE 18 as example

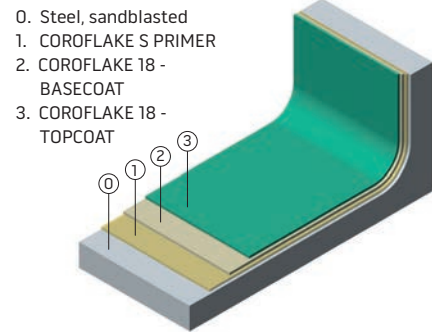

COROFLAKE spray coatings

The COROFLAKE systems, used throughout the world and applied with airless spraying equipment, combine the chemical resistance of trowelled coatings with the simplicity given by spraying. They are based on vinyl ester and epoxy-novolac resins, polyester resins and are either strengthened with C-glass, mineral or graphite flakes. In a 1 mm layer, around 100 flakes are arranged one above another and therefore form an outstanding diffusion resistance. Depending on exposure, two or more layers are applied to the substrate. The total thickness of the coating depends on the exposure and can be up to 2.5 mm thick. COROFLAKE spray coatings offer long-term economical protection of plant and a long service life. **High temperature-resistant COROFLAKE coatings can be used up to a maximum flue gas temperature of 230 °C.**

Typical build-up, using COROFLAKE 23 as example

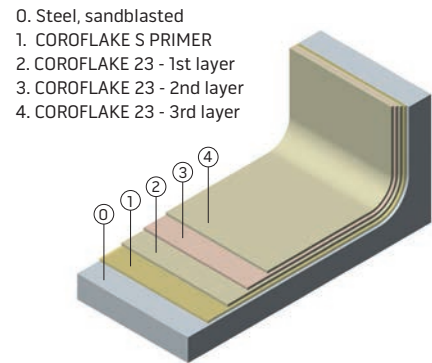

TOPLINE coatings

For these 3-4 mm thick glass mat reinforced coatings, polyester, vinyl ester, epoxy and epoxy-novolac resins are used. These coatings are characterized by their resistance to corrosion combined with excellent impact strength and abrasion resistance. If necessary, they can also be supplied in an electrically conducting form. The surfaces are grippy but non-porous and need no additional sealing. **They are primarily used in high-wear applications up to a wet temperature of 75 °C.**

Typical build-up, using TOPLINE W as example

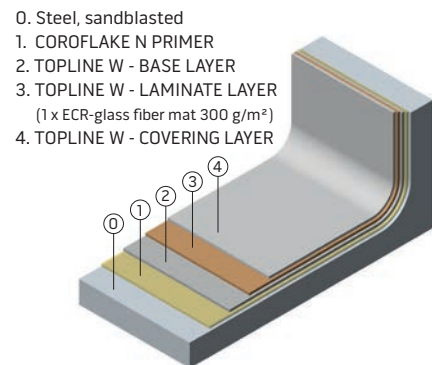

TIP TOP LINING

Using the same resins as the TOPLINE series, the high resin content ensures the best possible chemical resistance. The coating structure is formed by the application of a primer followed by a basecoat layer, at least two glass mats and a surface veil. A thick resin sealing coat finishes off this 3.0 to 5.0 mm thick laminate coating. By using strengthening glass mats and flexible base coat layers, cracks up to 0.2 mm wide can be bridged. **The TIP TOP LINING offers good mechanical resistance properties at wet temperatures of up to 80 °C.**

Typical build-up, using TIP TOP LINING 74 as example

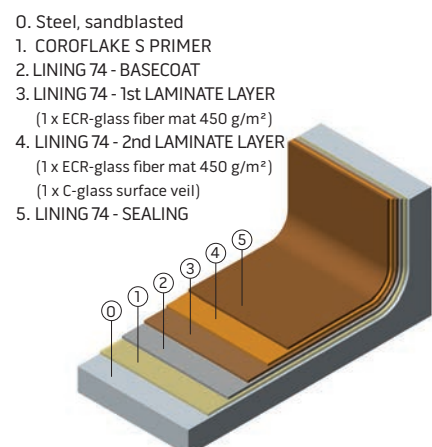

3. COATINGS FOR DRUMS AND ROLLERS

REMA TIP TOP is one of the leading suppliers for high-performance drum and roller laggings in a steadily-increasing market.

High-quality materials, generally based on polyurethane, have been used by us for many years. A specific form is made, exactly fitting to each individual component, the polyurethane coating being applied in a hot pouring process and subsequently tempered in an oven.



Drums coating with polyurethane

Special machines constructed for the treatment of rollers and drums permit us to manufacture dimensionally accurate coverings for all normal surface profiles.

REMA TIP TOP also produces highly wear-resistant ceramic coverings for drums.

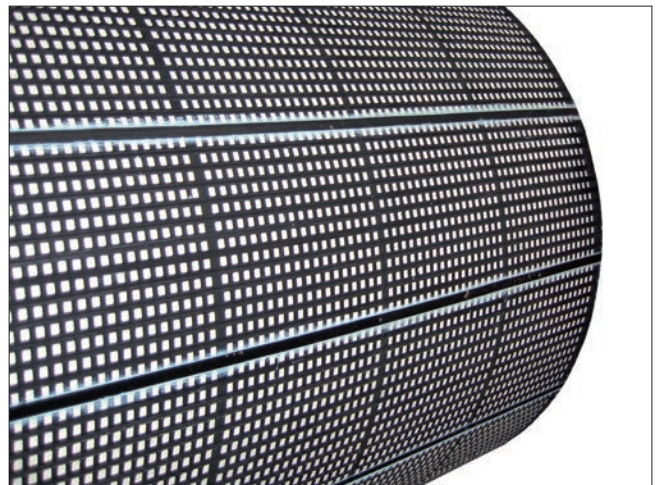

Lagging pulleys using CK-X ceramic coating

4. COATINGS FOR INDUSTRIAL FLOORING, COLLECTION PITS AND WAREHOUSES

REMA TIP TOP also provides a comprehensive range of coatings for these sectors, allowing it to meet almost all requirements encountered in practice.



WHG coating of an impounding basin in a galvanizing facility

With the brands TIP TOP LINING, Asplit and ESKANOL, we meet almost any requirement. A large number of our materials have general approval from the German Institute for Construction Technology (DIBt).

Water pollution control is a major concern in today's industrial production processes.

The German Federal Water Act (WHG) defines the requirement to lastingly protect ground water and water courses from chem-

icals and water-hazardous materials such as those found in production and warehousing. As a specialist with a long history of WHG experience, REMA TIP TOP is aware of its responsibility and your qualified partner for the planning and implementation of the required building measures.

Laminate, flow and trowelled coatings, as well as synthetic resin screeds, are used for industrial flooring, collection pits and warehouse flooring.



WHG coating in a shelf storage warehouse



Conductive WHG coating in a production hall



Installing a screed coating

4. COATINGS FOR INDUSTRIAL FLOORING, COLLECTION PITS AND WAREHOUSES

ESKANOL and Asplit flow coatings

These are self-levelling synthetic resin coatings containing mineral fillers with – in general – smooth high-gloss surfaces and a layer thickness of 1 to 3 mm. Self-levelling coatings can be quickly applied and are available in many visually appealing colour variants. Matt and anti-slip surfaces can also be produced by the addition of suitable supplements. Epoxy and the vinyl ester resins constitute the vast majority of the applications.

Typical build-up, using ESKANOL EF as example

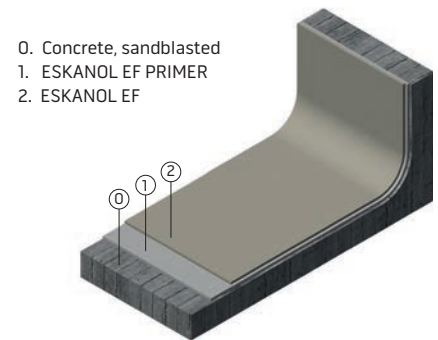

Asplit and ESKANOL trowelled coatings

Trowelled coatings split into those systems that are strengthened with glass-fiber mats, and high mineral content and manually applied coatings. Glass-fiber strengthened systems possess a high mechanical loading capacity. They are the solution of choice when the substrate tends to form cracks, while the other trowel coatings are often used as anti-wear coverings

Typical build-up, using Asplit ET TROWELLING as example

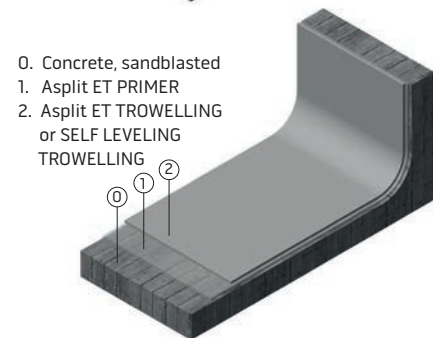

Asplit and ESKANOL synthetic resin screeds

For the floorings that are subject to extreme mechanical loads, epoxy based synthetic resin screeds are recommended. Application in layer thicknesses of 6 to 20 mm can be done manually or by machine. Synthetic resin screeds can be applied simply, quickly and seamlessly.

Typical build-up, using Asplit ET SCREED as example

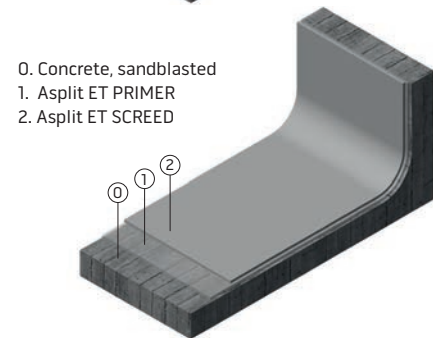

Laminate coatings

Laminate coatings are combinations of reaction resins with fiber materials (glass-fiber mats, fabrics). They are characterized by highly mechanical durability and even layer thicknesses. Their high durability qualifies them, for example, for use in bridging cracks in concrete parts that are to be coated.

Glass-fiber mats are of great importance for strengthening purposes, because the evenly spread fibers enable the mechanical strength characteristics to be increased in all directions. The mats often contain E-glass fibers and in special cases also ECR- or C-glass fibers. The mass per unit area (weights) are usually 300 or 450 g/m².

The applied glass mats are normally covered with a surface veil. In laminate coatings, they are used to build up the chemical protection layer. The surface veil materials mainly determine the coating surface and directly affect its chemical properties. The resin-rich surface veil layer that covers the laminate layer should exhibit a sealed and even surface to prevent media penetration via glass fibers that have not been saturated in the resin. By preference, surface veils made of durable C-glass are used. Surface veils made from synthetic or carbon fibers offer resistance to special media such as hydrofluoric acid. Carbon-fiber surface veils, also known as hybrid surface veils, additionally impart an electrostatically conducting quality to the cover layer. The mass per unit area (weight) of these veils 20 to 50 g/m². REMA TIP TOP uses synthetic resins based on furane, phenol, vinylester and epoxy for its laminate coatings, which are distributed under the brand names TIP TOP LINING, ESKANOL and Asplit.

Typical build-up, using TIP TOP LINING 74 as example

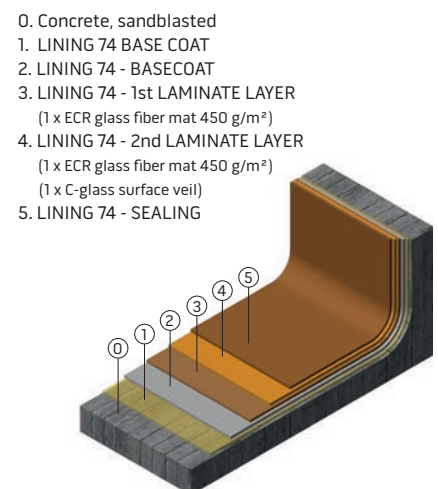

5. FLUOROPOLYMER LININGS

In particularly critical application areas such as in heat exchanger casings or raw gas ducts, which are continually exposed to acids at high temperature, we use linings based on PFA (Tetrafluoroethylene-Perfluoroalkylvinylether).

This lining is characterized by a high resistance to temperature and acids. These are known as fixed-point linings. The PFA foil is mechanically attached to the substrate at an exactly calculated number of fixing points.

Our special REMAFLON material, based on PTFE (polytetrafluoroethylene) with an easy-to-bond layer is used in areas where non-stick properties are needed in order to, for example, avoid caking.



PFA lining in a raw gas duct



REMAFLON as non-stick lining in a flue gas ventilator



PFA lining in a raw gas duct

6. ACID-PROOF BRICK LININGS

In addition to protection against thermal and mechanical stresses, our acid-proof brick linings offer a high degree of chemical resistance.

Wherever high chemical stresses, temperature and wear combine in such a way that linings, coatings or even high-alloy stainless steels cannot be recommended, acid-proof brick linings, proven across decades, are used.

Combined system build-ups are matched perfectly to the membrane – whether rubber lining or synthetic resin-based coating – consisting of acid-proof bricks, carbon or graphite bricks or insulating bricks or wear-resistant ceramics in conjunction with suitable synthetic resin or potassium silicate mortar from REMA TIP TOP, guarantee maximum service life and economic return.

Our acid-proof brick linings are mainly used in pickling plants, sulfuric and phosphoric acid plants as well as in autoclaves, flue gas scrubbers and many other areas.

Our experienced constructors and application engineers exactly analyze the current loads and stresses, and study the whole process to build up the ideal composition of the materials.

Under the CHEMOKITT and Asplit brand names, REMA TIP TOP offers a broad range of synthetic resin and potassium silicate mortars. Our range of over 10 different synthetic resin and potassium silicate mortars, each designed with its own special characteristics, means that we can meet almost any demand.



Working with synthetic resin mortar

6. ACID-PROOF BRICK LININGS



Vessel lined with carbon bricks and CHEMOKITT FU 1320



HCl pickling tank lined with ceramic bricks and CHEMOKITT FU 1310

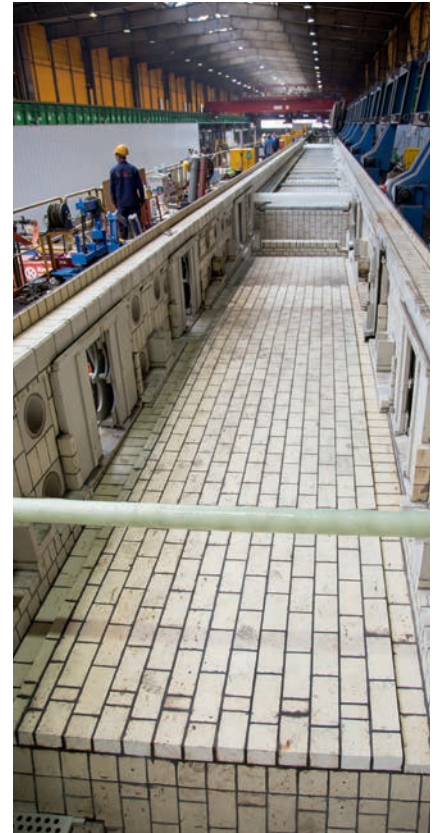

Brick lined pickling tank

CHEMOKITT

Under the CHEMOKITT brand name, REMA TIP TOP offers synthetic resin mortars based on furane, vinyl ester, polyester and epoxy resin. CHEMOKITT synthetic resin mortars are particularly suitable for lining phosphoric acid tanks as well as pickling tanks and reaction vessels.

Typical Build-up, using CHEMOKIT FU 1320 with carbon bricks as example

0. Steel, sandblasted
1. CHEMOLINE 4 B
2. CHEMOKITT FU 1320
3. Carbon bricks, 65 mm

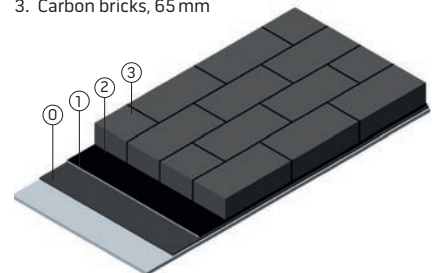

Asplit mortars

Our range of lining materials is completed by Asplit mortars, well established for over 50 years in all types of process plants. Asplit mortars are characterized by an excellent chemical resistance even at extreme operating temperatures. Asplit mortars are manufactured on the basis of phenol, furane, vinyl ester, polyester and epoxy resins and potassium silicate. Highly wear-resistant grouting mortars are also available for the laying of fused cast basalt. Mortars from the Asplit range are primarily used in sulfuric acid plant, reaction vats and many other areas.

Typical Build-up, using Asplit CN with ceramic bricks as example

0. Steel, sandblasted
1. Asplit LC LAMINAT
2. Asplit CN
3. Ceramic bricks, 65 mm

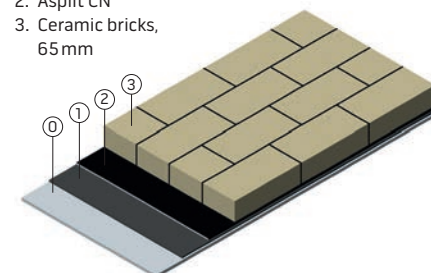

7. ACID-PROOF AND HEAVY-DUTY CORROSION PROTECTION WITH COMBINED LININGS

Acid proofing is required in all industrial operations where chemicals are produced, processed, stored or transported. The mechanical, thermal or chemical resistance of floor or wall coatings is often insufficient for the conditions and stresses involved.

Combined coatings, consisting of a membrane and ceramic tiles or bricks set in synthetic resin mortar, are used to withstand the most extreme conditions. Rubber coatings and crack-bridging synthetic resin coatings are used as the membrane.

We also offer high-quality rectangular or hexagonally shaped tiles that are primarily used in the pharmaceutical and food industry. The combined linings used and described utilize the same membranes and synthetic resin mortars that have already been described in previous chapters.

One of our specialties is the manufacturing of high-quality poly-concrete bricks for acid-proof construction. Polyconcrete bricks are mainly used for pumps, equipment foundations and floor trenches of any size.

We plan and implement acid-proofing measures individually based on the requirements of our clients.



Polly-concrete bricks as pumping equipment foundation



Hexagonal tile coverings in the pharmaceutical industry

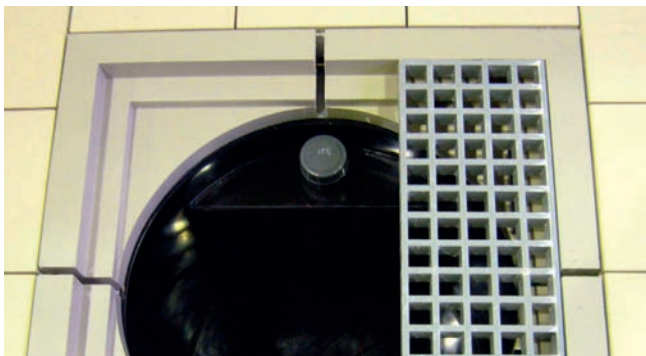

Double-walled pump sump



Combined covering implemented with gutters

Typical build-up of a combined lining, using as example CHEMOLINE 4 CN + ceramic tiles in CHEMOKITT FU 1310

0. Concrete, sandblasted
1. CHEMOLINE 4 CN
2. CHEMOKITT FU 1310
3. Ceramic tiles, 25mm

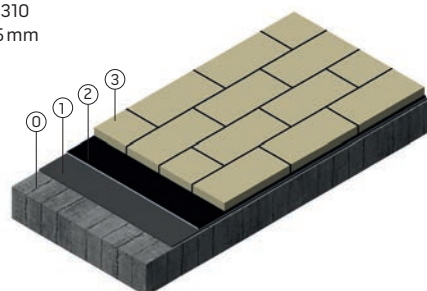

8. OUR SERVICE BENCHMARK – A PERFECT PROCESS

Your absolute satisfaction is our highest priority. We guarantee high standard of quality – for both our products and the service we deliver. We leave nothing to chance and work to very high standards.

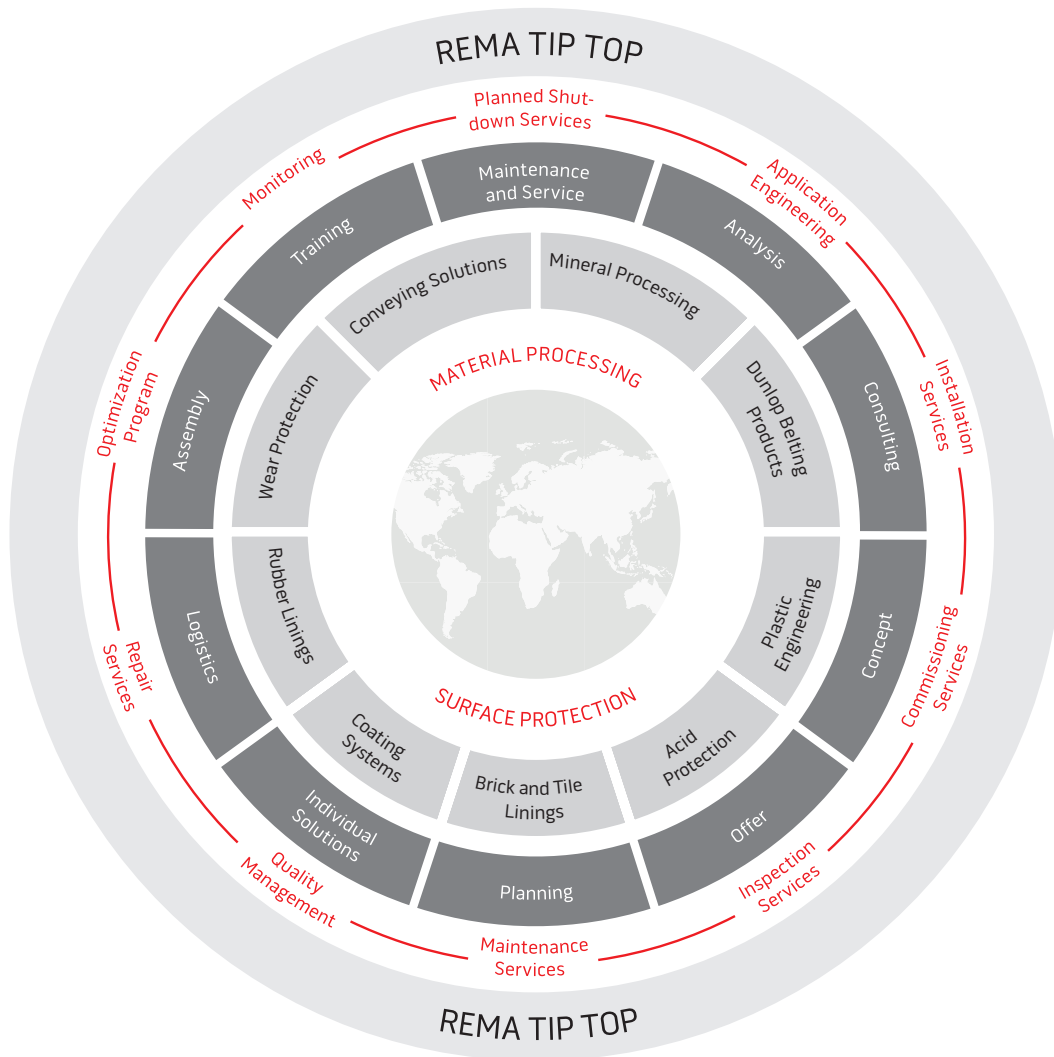

Technical lining and coating processes in our facilities and on the construction site:

- Advising, development, selection of materials
- Checking of parts according to EN 14879-1
 - Construction design
 - Ability to install lining
- Surface treatment according to EN ISO 12944-4 and EN ISO 8503-2 with control of surface and sandblasting quality
- Application of primer and bonding agent
- Application of corrosion protection materials in accordance with EN 14879 Parts 2 - 6
- Quality control after each work step
- Documentation for checks carried out
- Final inspection – issuing of certificate
- After-sales service

All REMA TIP TOP materials are produced in accordance with the latest process technologies in our own production facilities. The highest quality assurance measures (certification according to EN ISO 9001) ensure that all products and technologies used always comply with, and often exceed, the latest country-specific regulations and standards. Our trained specialists ensure that these measures are adhered to throughout the entire production process, from order acceptance to shipping and after-sales service.

Notes



TIP TOP Oberflächenschutz Elbe GmbH
Heuweg 4
06886 Wittenberg / Germany
Phone: +49 (0) 3491 6355 0
info@tiptop-elbe.de

→ www.tiptop-elbe.com

Your local contact



// ONE BRAND // ONE SOURCE // ONE SYSTEM

REMA TIP TOP AG
Gruber Strasse 65 · 85586 Poing / Germany
Phone: +49 8121 707-100
Fax: +49 8121 707-10 222
info@tiptop.de
www.rema-tiptop.com

